

## Y-check valve type 35



Body material	PVC-U	PP	PVDF
Sealing material (optionally)	• EPDM		• FKM
Working temperature	0 °C up to 60 °C <sup>1)</sup>	-20 °C up to 80 °C <sup>1)</sup>	-20 °C up to 120 °C <sup>1)</sup>
Nominal size	DN 15 up to DN 50		
Connection with pipe	• Cement spigot	• True union with -cement- / welding socket -welding spigot	• Flange with dimensions acc. to DIN EN 1092-1 (replaces DIN 2501) - PN 10/16
Length	• Company standard		• DIN EN 558-1 series FTF 1 (DIN 3202 - series F 1)

<sup>1)</sup> Working temperatures for sealing materials:

EPDM: -20 up to 90 °C

FKM: -20 up to 120 °C

### Example for an invitation to tender text:

Y-check valve type 35, DN 25, PN 16, PVDF / FKM true union with welding socket PVDF and Spring (PTFE coated)

**Document:** FRANK\_DB\_L5\_Schrägsitz-Rückschlagventil Typ 35\_04-2012\_EN

## Y-check valve type 35, PVC-U

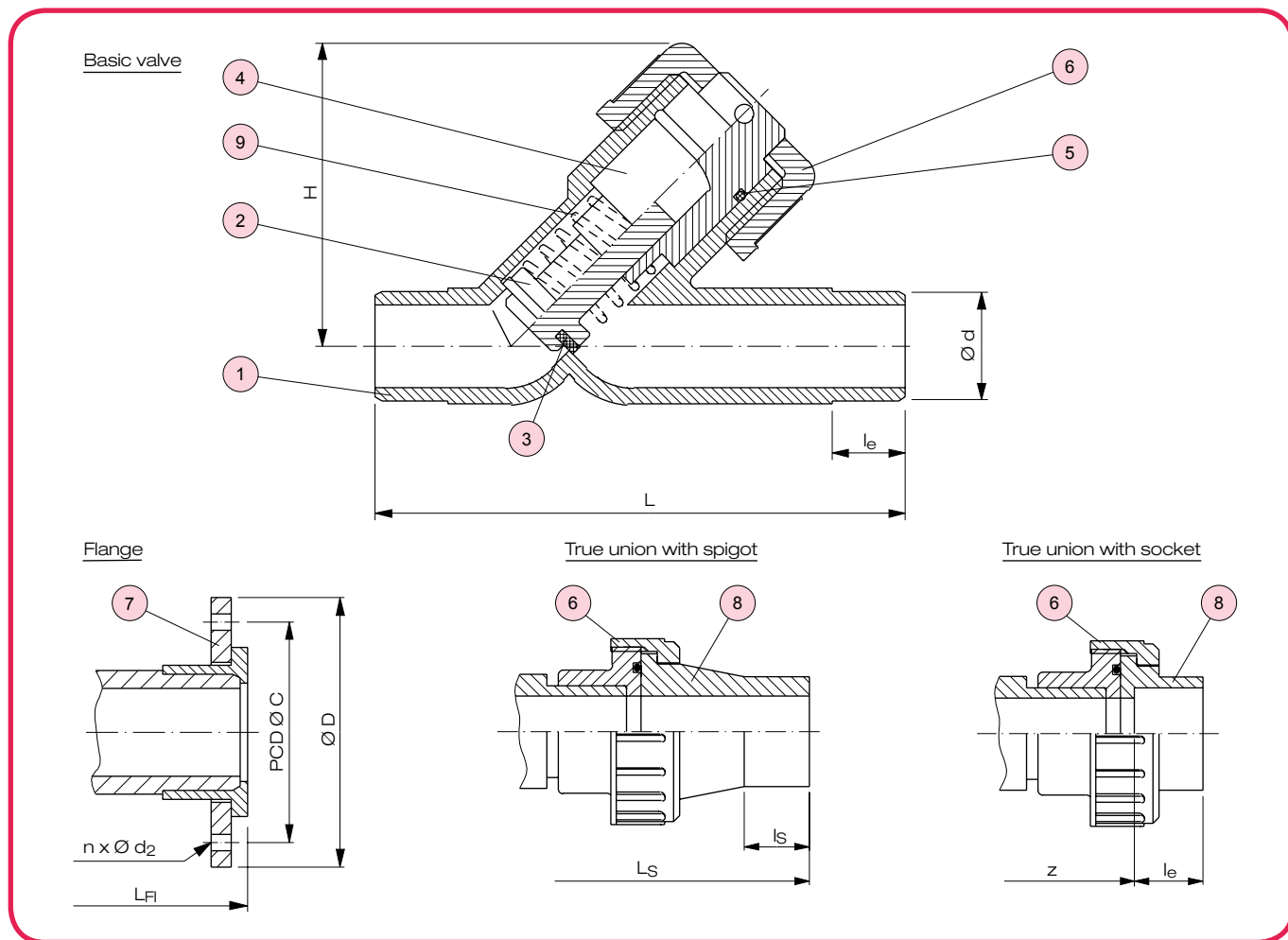

No.	Description	Number	Material
1	Body	1	PVC-U
2	Cylinder <sup>*)</sup>	1	PVC-U
3	Cylinder seal <sup>*)</sup>	1	EPDM, FKM <sup>3)</sup>
4	Cylinder guide	1	PVC-U
5	O-ring <sup>*)</sup>	1	EPDM, FKM

<sup>\*)</sup> Wearing parts

<sup>1)</sup> for flanged version

<sup>2)</sup> for true union version with socket / spigot

No.	Description	Number	Material
6	Union nut	1	PVC-U
7	Collar joint and flange <sup>1)</sup>	1	PVC-U
8	Union with joint <sup>2)</sup>	2	PVC-U, PE/EPDM, FKM <sup>3)</sup>
9	Spring <sup>4)</sup>	1	Spring steel, PTFE coated

<sup>3)</sup> Special version: CSM, NBR, FEP / Parofluor on request

<sup>4)</sup> Standard version without spring

### Dimensions and weights

Dimensions in mm													Weight in kg / pc.		
DN	d	H	Spigot		Flange				True union Socket / spigot				Basic valve	Flange	True union Socket / spigot
			L	l <sub>e</sub>	L <sub>Fl</sub>	D	n x d <sub>2</sub>	C	z	l <sub>e</sub>	L <sub>S</sub>	l <sub>s</sub>			
15	20	75	124	17	130	95	4 x 14	65	150	16	252	38	0,18	0,36	0,26
20	25	80	144	18	150	105	4 x 14	75	170	18	278	39	0,20	0,46	0,33
25	32	90	154	20	160	115	4 x 14	85	180	20	294	39	0,30	0,67	0,50
32	40	110	174	23	180	140	4 x 18	100	204	22	320	42	0,48	1,03	0,84
40	50	128	194	26	200	150	4 x 18	110	228	24,5	342	44	0,79	1,42	1,21
50	63	150	224	30	230	165	4 x 18	125	266	29	384	44	1,32	2,30	2,04

### Minimum required shut and opening pressures in mbar

DN	15	20	25	32	40	50
Closing	18	23	35	45	45	45
Opening	10	10	10	10	10	10

# Y-check valve type 35, PP and PVDF

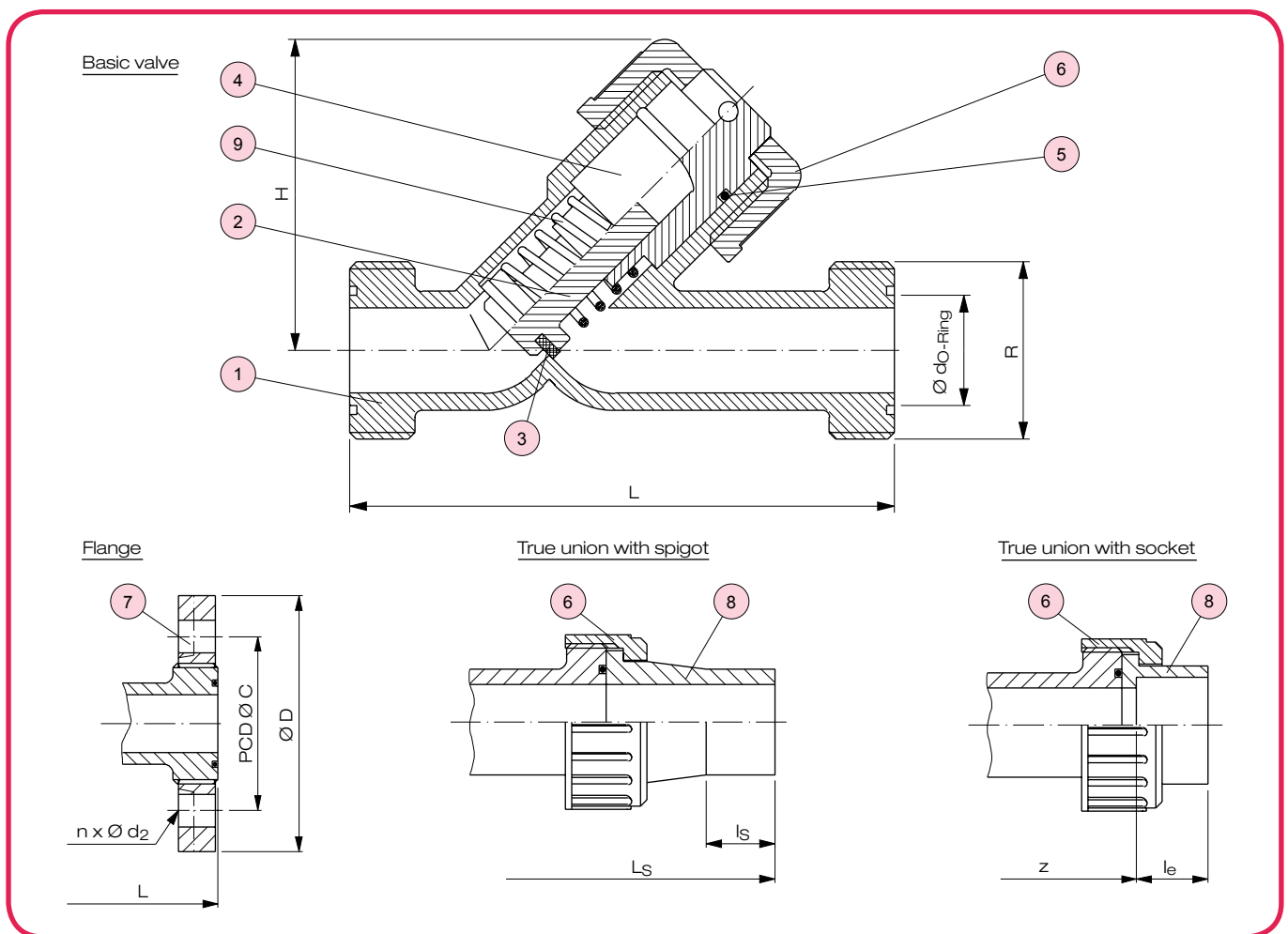

No.	Description	Number	Material
1	Body	1	PP, PVDF
2	Cylinder <sup>*)</sup>	1	PP, PVDF
3	Cylinder seal <sup>*)</sup>	1	EPDM, FKM <sup>3)</sup>
4	Cylinder	1	PP, PVDF
5	O-ring <sup>*)</sup>	1	EPDM, FKM

No.	Description	Number	Material
6	Union nut	1	PP, PVDF
7	Threaded flange <sup>1)</sup>	1	PP, PP-GFK
8	Union with joint <sup>2)</sup>	2	PP, PVDF/EPDM, FKM <sup>3)</sup>
9	Spring	1	Spring steel, PTFE coated

<sup>\*)</sup> Wearing parts

<sup>1)</sup> for flanged version

<sup>2)</sup> for rue union version with socket / spigot

<sup>3)</sup> Special version: CSM, NBR, FEP / Parofluor on request

## Dimensions and weights

Dimensions in mm													Weight in kg / pc.			
DN	Basic valve					Flange			True union Socket / spigot				Basic valve		Flange	
	d	d <sub>O-ring</sub>	H	L	R	D	n x d <sub>2</sub>	C	z	le	L <sub>S</sub>	l <sub>S</sub>	PP	PVDF	PP	PVDF
15	20	20,22 x 3,53	75	130	36 x 1/8"	95	4 x 14	65	136	16	238	38	0,14	0,27	0,16	0,45
20	25	29,75 x 3,53	80	150	48 x 1,6"	105	4 x 14	75	156	18	264	39	0,16	0,31	0,18	0,57
25	32	36,09 x 3,53	90	160	52 x 1,6"	115	4 x 14	85	166	20	280	39	0,24	0,47	0,27	0,81
32	40	40,64 x 5,33	110	180	65 x 1,6"	140	4 x 18	100	186	22	306	42	0,39	0,77	0,43	1,35
40	50	46,99 x 5,33	128	200	72 x 1,6"	150	4 x 18	110	206	24,5	334	44	0,60	1,15	0,67	1,81
50	63	59,69 x 5,33	150	230	85 x 1,6"	165	4 x 18	125	230	29	368	44	1,02	1,65	1,08	2,43

## Minimum closing pressures

DN	15	20	25	32	40	50	
Closing press. [bar]	without spring	0,18	0,23	0,20	0,30	0,30	0,20
	with spring	0,01	0,01	0,01	0,01	0,01	0,01

## Minimum opening pressures

DN	15	20	25	32	40	50	
Opening press. [bar]	without spring	0,01	0,01	0,01	0,01	0,01	0,01
	with spring	0,20	0,30	0,20	0,30	0,40	0,20

# Y-check valve type 35

## Pressure loss diagram

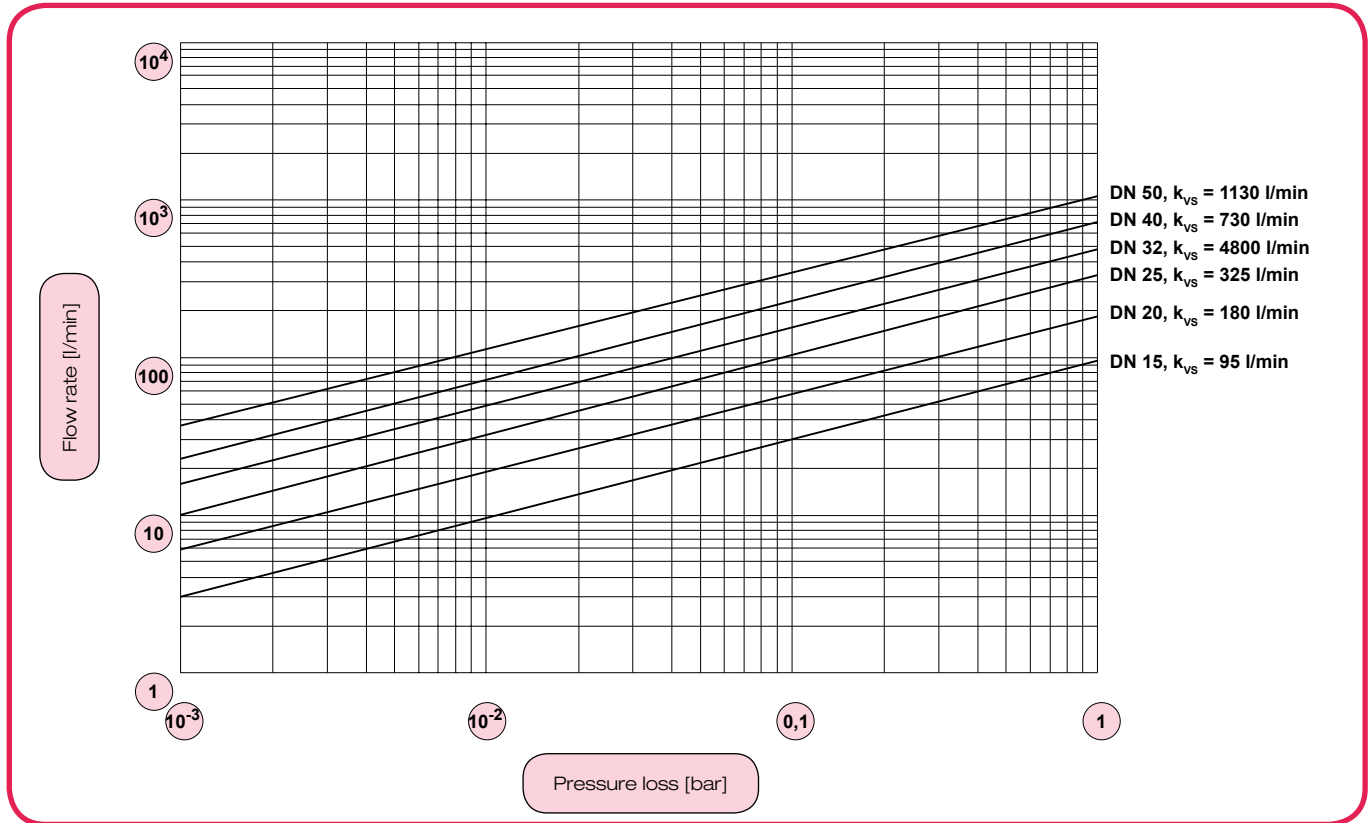

### Operating instructions

Working pressure<sup>1)</sup>  $p_B$  in bar

Body material	$T_B$ in °C	$p_B$ [bar]
PVC-U	0 up to 20	10
	40	6
	60	1
PP	-20 up to 30	10
	60	4,2
	80	1,5
PVDF	-20 up to 20	16
	80	10
	120	4

<sup>1)</sup> Definition see chapter T2 / technical information

#### Maintenance

- Depending on the application, the valve has to be maintained and cleaned in regular intervals.

#### Disassembly of the valve

**Attention:** Never dismantle the valve when the pipe is under pressure.

- Loosen and tighten union nuts 6 by hand or with a strap wrench. Do not handle the parts by force.
- Loosen union nut 6 and carefully pull cylinder guide 4 out of the body 1.
- Pull cylinder 2 out of the cylinder guide 4 and carefully remove the cylinder seal 3 from the cylinder with a suitable tool.
- Remove the o-ring 5 from its seat.

**Attention:** Use suitable tools for the o-rings to prevent them from being damaged.

#### Assembly of the valve

- The valve assembly is to be performed in reverse order to the disassembly.
- Before the assembly all parts have to be checked for damages.
- All parts have to be clean.
- For assembly of o-ring 5 a silicone-free lubricant may be used.
- After assembly carry out a pressure test acc. to DIN EN 12266-1.

#### Notes for correct installation

- The valve must be installed stress-free in the pipe (plane parallelism, axial, overall length).
- Flanged connection:  
The flange bolts have to be tightened equably.  
In general, use washers for the nuts and bolts in plastic flanges.
- Socket and spigot joint:  
The cementing or welding process has to be performed acc. to the relevant guidelines (e. g. DVS).
- The valve has to be installed with direction indicator pointing in flow direction.