

Ball check valve type 31 and type 32, ball foot valve type 30



Body + ball material ¹⁾	PVC-U	PVC-C	PP	PVDF
Sealing material (optionally)	• EPDM		• FKM	• FKM-F
Working temperature	0 °C up to 50 °C ²⁾	0 °C up to 90 °C ²⁾	-20 °C up to 80 °C ²⁾	-20 °C up to 100 °C ²⁾
Nominal size	DN 15 up to DN 100 (type 31 = DN 15 up to DN 50)			
Connection with pipe	cement- / welding socket, welding spigot Flange connection acc. to DIN EN 1092-1 (replaces DIN 2501) - PN 10/16 ^{*)}			
Length	Company standard			

¹⁾ Special version with hollow ball on request
^{*)} also acc. to ANSI available

²⁾ Working temperatures for sealing materials:
 EPDM: -20 up to 90 °C
 FKM / FKM-F: -5 up to 100 °C

Example for an invitation to tender text:

Ball check valve type 32, DN 100, PN 7, PVC-U / EPDM, cement socket d 110

Document: FRANK_DB_L5_Ball check valve type 31 and type 32, ball foot valve type 30_09-2012_EN

Ball check valve type 32

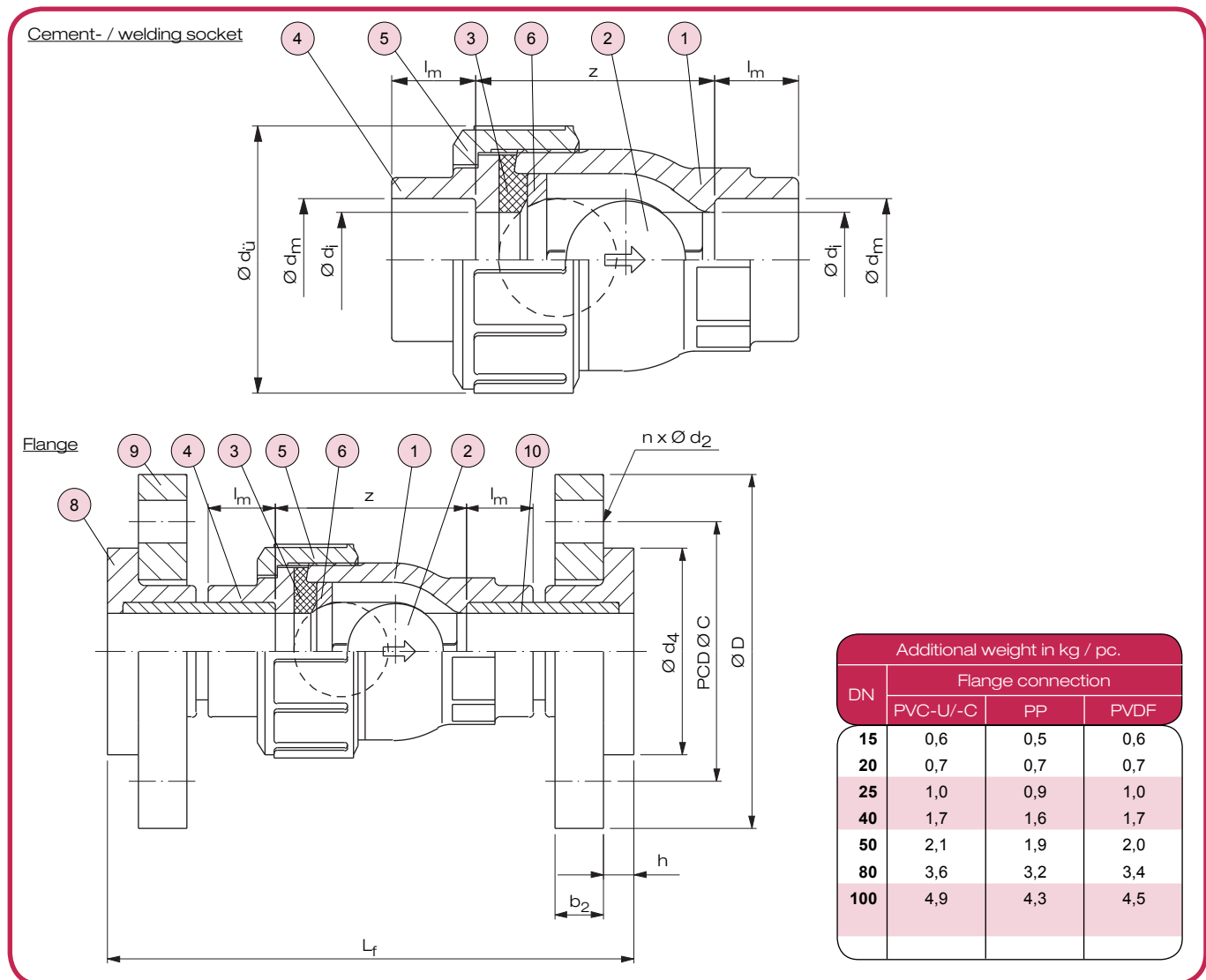

No.	Description	Number	Material
1	Body	1	PVC-U, PVC-C, PP, PVDF
2	Ball ^{*)}	1	PVC-U, PVC-C, PP, PVDF
3	Ball seat ^{*)}	1	EPDM, FKM
4	End connector (Cement- / welding socket)	1	PVC-U, PVC-C, PP, PVDF

^{*)}Wearing parts

¹⁾version flange

No.	Description	Number	Material
5	Union nut	1	PVC-U, PVC-C, PP, PVDF
6	Thrust ring	1	PVC-U, PVC-C, PP, PVDF
8	Flange adaptor ¹⁾	2	PVC-U, PVC-C, PP, PVDF
9	Flange ¹⁾	2	PPG with steel core
10	Pipe ¹⁾	2	PVC-U, PVC-C, PP, PVDF

Dimensions and weights

Dimensions in mm															Weight in kg / pc.				
DN	Cement socket				Welding socket				Flange connection							Cement socket		Welding socket	
	d _i	d _u	z	d _m	l _m	d _m	l _m	b ₂	h	K	D	L _f	d ₄	n x d ₂	PVC-U	PVC-C	PP	PVDF	
15	15	48	50	20	16	19,5	14,5	12	10	65	95	130	45	4 x 14	0,09	0,12	0,06	0,12	
20	20	60	59	25	19	24,5	16	12	10	75	105	150	58	4 x 14	0,15	0,20	0,10	0,20	
25	25	70	63	32	22	31,5	18,1	16	10	85	115	160	68	4 x 14	0,24	0,30	0,15	0,30	
40	40	96	90	50	31	49,45	23,5	18	13	110	150	230	88	4 x 18	0,55	0,75	0,35	0,75	
50	51	106	107	63	38	62,5	27,4	18	13,7	125	165	270	101	4 x 18	0,78	1,00	0,50	1,00	
80	78	152	150	90	51	89,2	35,5	20	16,3	160	200	370	138	8 x 18	2,26	2,80	1,60	2,80	
100	100	210	209	110	61	109,1	41,5	20	18	180	220	470	158	8 x 18	6,00	7,20	4,00	7,20	

Ball check valve type 31

Cement- / welding socket - true union

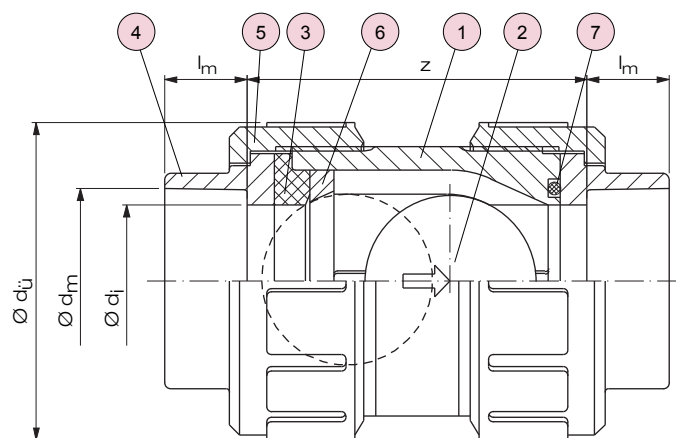

Flange connection
(type 32)
see page L5-2

Welding spigot - true union

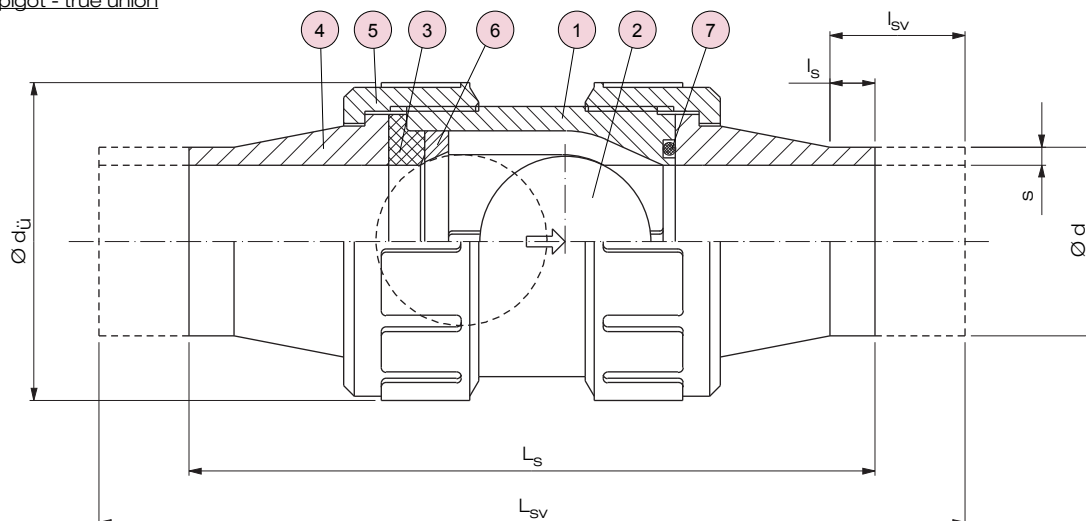

No.	Description	Number	Material
1	Body	1	PVC-U, PVC-C, PP, PVDF
2	Ball ^{*)}	1	PVC-U, PVC-C, PP, PVDF
3	Ball seat ^{*)}	1	EPDM, FKM
4	End connector (Cement- / welding socket)	2	PVC-U, PVC-C, PP, PVDF

^{*)}Wearing parts

No.	Description	Number	Material
5	Union nut	2	PVC-U, PVC-C, PP, PVDF
6	Thrust ring	1	PVC-U, PVC-C, PP, PVDF
7	O-ring ^{*)}	1	EPDM, FKM

Dimensions and weights

DN	Dimensions in mm														Weight in kg / pc.			
	Cement socket		Welding socket		Spigot								Cement socket		Welding socket			
	d _j	d _ü	d _m	l _m	d _m	l _m	d	s SDR 11	l _{sv}	l _s	L _{sv}	L _s	PVC-U	PVC-C	PP	PVDF		
15	15	48	53	20	16	19,5	14,5	20	1,9	64	30	202	144	0,09	0,12	0,06	0,12	
20	20	60	62	25	19	24,5	16	25	2,3	61	25	225	151	0,15	0,20	0,10	0,20	
25	25	70	69	32	22	31,5	18,1	32	3,0	61	25	235	155	0,24	0,30	0,15	0,30	
40	40	96	97	50	31	49,45	23,5	50	4,6	69	22	283	179	0,55	0,75	0,35	0,75	
50	51	106	116	63	38	62,5	27,4	63	5,8	78	20	343	193	0,78	1,00	0,50	1,00	

Ball foot valve 30

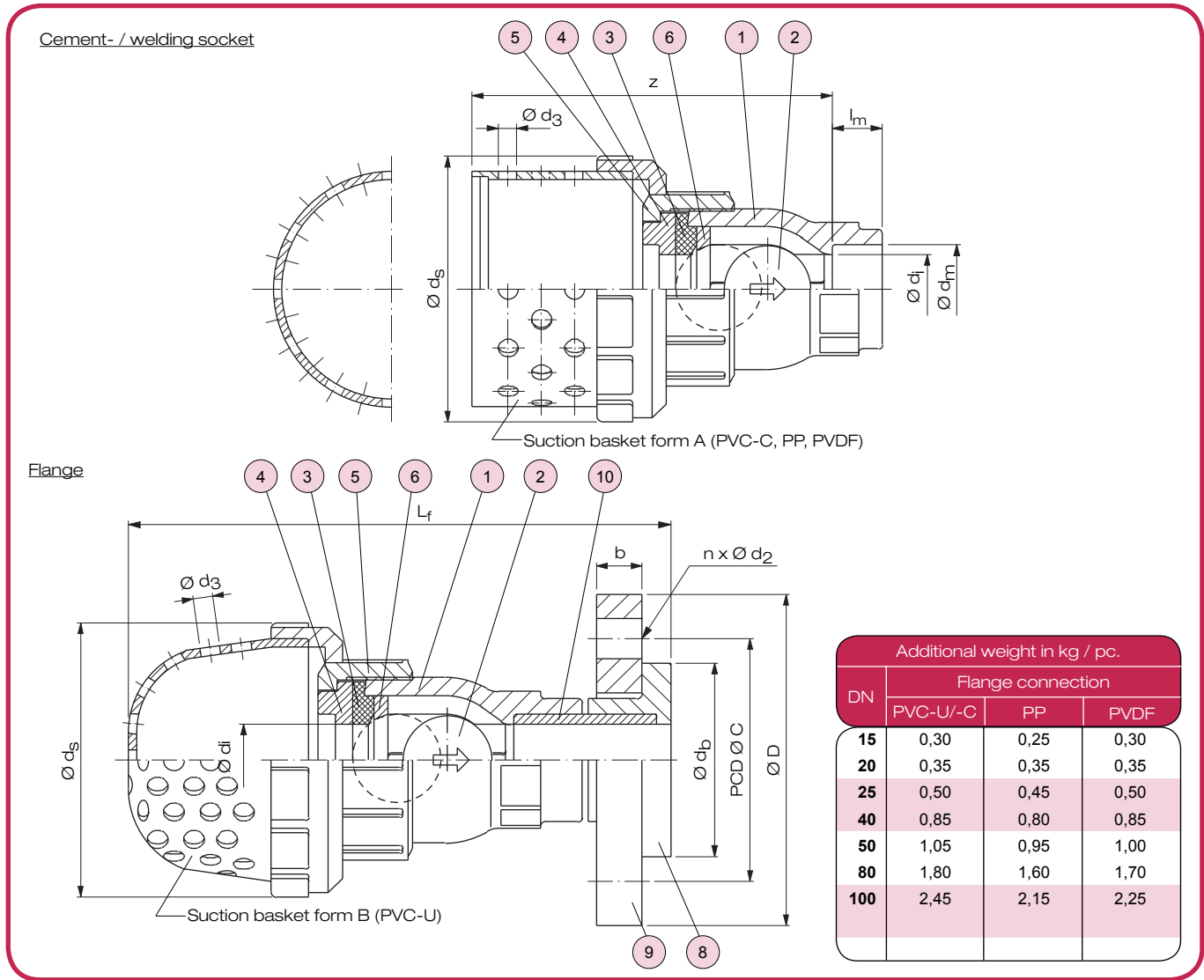

No.	Description	Number	Material
1	Body	1	PVC-U, PVC-C, PP, PVDF
2	Ball ¹⁾	1	PVC-U, PVC-C, PP, PVDF
3	Ball seat ¹⁾	1	EPDM, FKM
4	End connector (Cement- / welding socket)	1	PVC-U, PVC-C, PP, PVDF

No.	Description	Number	Material
5	Union nut with suction basket	1	PVC-U, PVC-C, PP, PVDF
6	Thrust ring	1	PVC-U, PVC-C, PP, PVDF
8	Flange adaptor ¹⁾	1	PVC-U, PVC-C, PP, PVDF
9	Flange ¹⁾	1	PPG with steel core
10	Pipe ¹⁾	1	PVC-U, PVC-C, PP, PVDF

¹⁾Wearing parts

¹⁾version flange

Dimensions and weights

DN	Dimensions in mm														Weight in kg / pc.			
	Cement socket		Welding socket		Flange connection								Cement socket		Welding socket			
	d _i	d _s	d ₃	z	d _m	l _m	d _m	l _m	b	h	K	D	L _f	n x d ₂	PVC-U	PVC-C	PP	PVDF
15	15	60	6	100	20	16	19,5	14,5	12	10	65	95	136	4 x 14	0,1	0,2	0,1	0,2
20	20	70	6	115	25	19	24,5	16	12	10	75	105	150	4 x 14	0,2	0,3	0,2	0,3
25	25	96	7	133	32	22	31,5	18,1	16	10	85	115	164	4 x 14	0,3	0,4	0,2	0,5
40	40	133	10	178	50	31	49,45	23,5	18	13	110	150	217	4 x 18	1,0	1,3	0,7	1,4
50	51	133	10	191	63	38	62,5	27,4	18	13,7	125	165	236	4 x 18	1,4	1,6	0,9	1,7
80	78	210	12	330	90	51	89,2	35,5	20	16,3	160	200	391	8 x 18	4,1	4,7	2,4	4,8
100	100	260	16	406	110	61	109,1	41,5	20	18	180	220	477	8 x 18	10,9	12,7	6,3	12,9

Ball check valve type 31 and type 32, ball foot valve type 30

Flow rate characteristic value¹⁾ k_{VS} in m^3/h

DN	15	20	25	40	50	80	100
k_{VS} [m^3/h]	5,6	14,7	22	74	112	242	433

¹⁾ Definition k_{VS} -value see chapter T2 / technical information

Hydrostatic bursting pressure²⁾ in bar at 22 °C

DN	15	20	25	40	50	80	100
PVC-U	5,6	14,7	22	74	112	242	433

²⁾ Definition see chapter T2 / technical information

Minimum required shut and opening pressures
in bar (medium air)

DN	Vertical installation		Horizontal installation	
	Opening	Closing	Opening	Closing
15	0,05	0,2	0,01	0,2
20, 25	0,05	0,3	0,01	0,3
40	0,05	0,3	0,01	0,3
50	0,1	0,3	0,02	0,3
80	0,1	0,3	0,02	0,3
100	0,1	0,3	0,02	0,3

Working pressure³⁾ p_B in bar

Body material	T_B in °C	DN	
		10 - 50	80, 100
PVC-U	0 up to 50	10	7
	60	8	6
	80	6	4
	90	4	3
PVC-C	-20 up to 30	10	5
	60	6	4
	80	4	3
PP	-20 up to 60	10	7
	80	8,5	6
	90	7,5	4
PVDF	100	6	3

³⁾ Definition see chapter T2 / technical information

Vacuum resistance⁴⁾ in bar

DN 15-100	
PVC-U, PVC-C, PP, PVDF	1,0

⁴⁾ Valid within the range of working temperatures

Pressure loss diagram

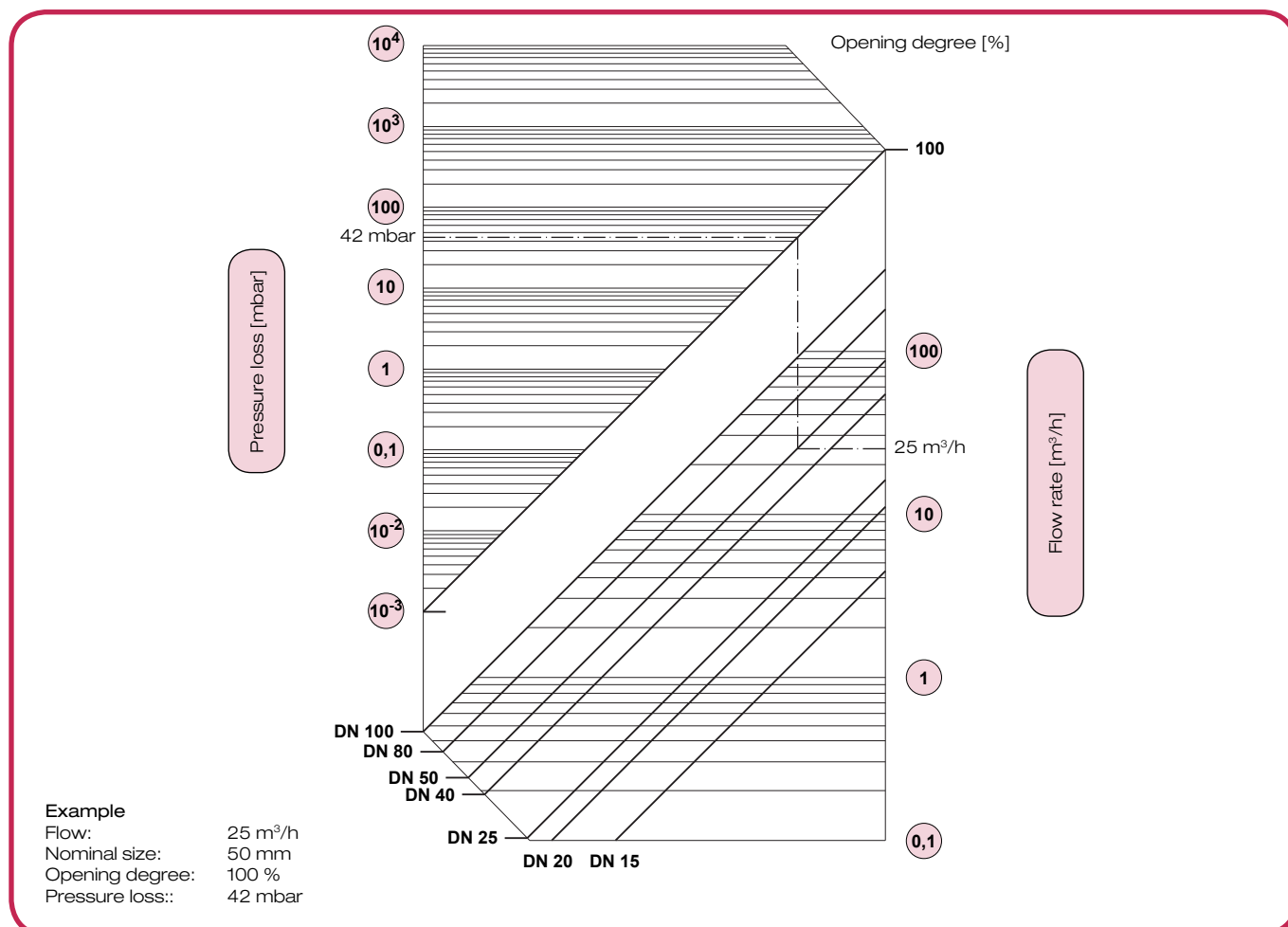

Ball check valve type 31 and type 32, ball foot valve type 30

Assembly and disassembly

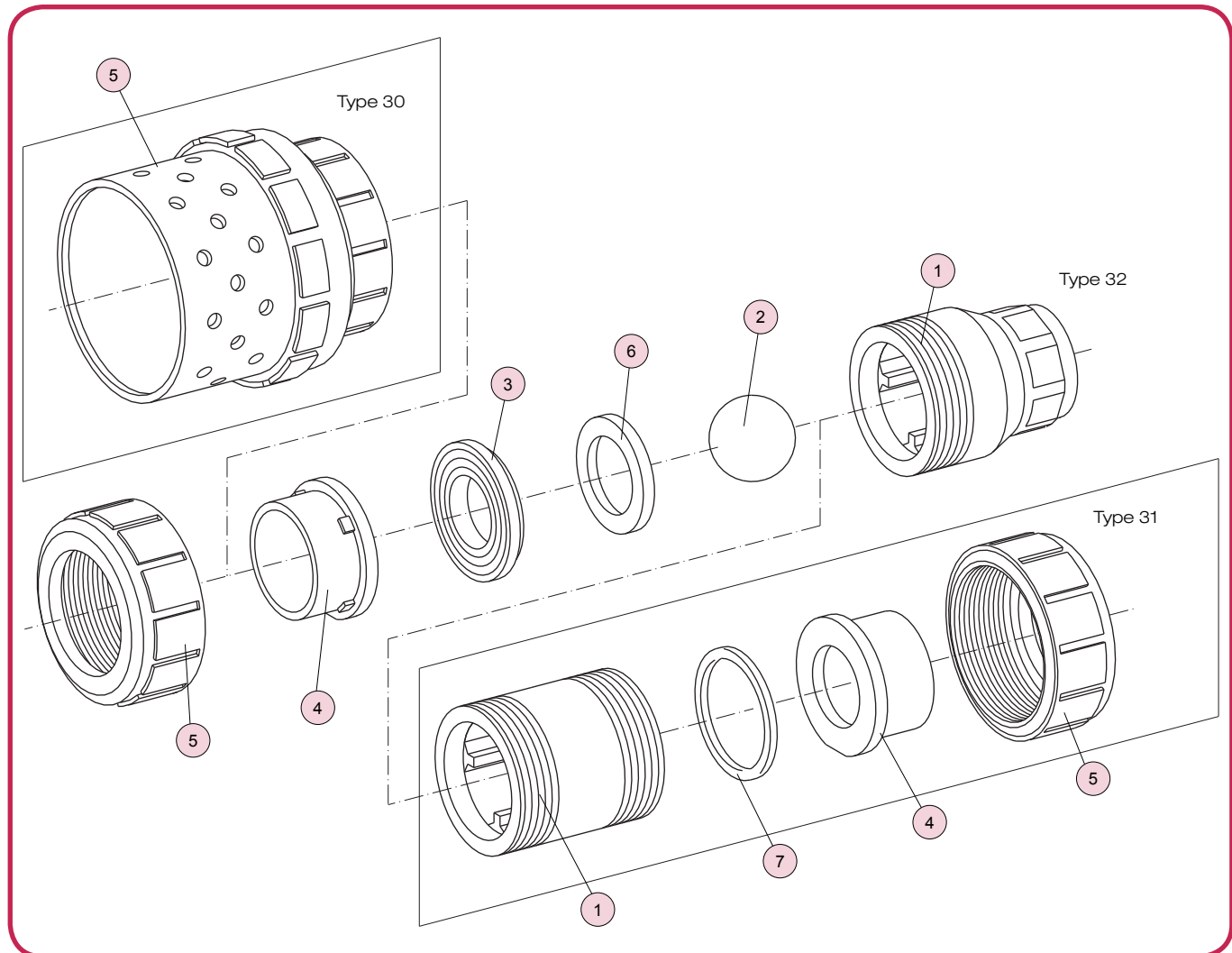

all sizes

Disassembly of the valve

Attention: Never dismantle the valve when the pipe is under pressure.

- Remove the valve depending on the connection after loosening the union nut 5, respectively flange connection screws (version flange connection) out of the pipe line.
- Advice: The union nuts 5 have to be loosened by hand or by strap wrench (avoid violent application).
- *Type 30:* Loosen the union nut 5 with the suction basket and remove it.
- *Type 32:* Remove the o-ring from the groove of the body 1.
- Remove the ball seat 3 and thrust ring 6 carefully from the body 1.
- Remove ball 2 out of the Body 1.

Assembly of the valve

- The valve assembly is to be performed in reverse order to the disassembly.
- Before the assembly all parts have to be checked for damages.
- All parts have to be clean.
- After assembly carry out a pressure test acc. to DIN EN 12266-1.

Notes for correct installation

- The valve must be installed stress-free in the pipe (plane parallelism, axial, overall length).
- Flange connection:
The flange bolts have to be tightened equably (tightening torques). In general, use washers for the nuts and bolts in plastic flanges.
- Socket and spigot joint:
The cementing or welding process has to be performed acc. to the relevant guidelines (e. g. DVS).