

Ball valve type 21



Body material	PVC-U	PVC-C	PP	PVDF
Ball seat	PTFE			
Other seats	• EPDM	• FKM	• *)	• FKM-F
Working temperature	0 °C up to 50 °C ¹⁾	0 °C up to 90 °C ¹⁾	-20 °C up to 80 °C ¹⁾	-20 °C up to 100 °C ¹⁾
Nominal size	DN 10 up to DN 100			
Connection with pipe	<ul style="list-style-type: none"> • Cement socket or spigot • Flange connection acc. to DIN EN 1092-1 (replaces DIN 2501) - PN 10/16 		<ul style="list-style-type: none"> • Welding socket or spigot • Threaded socket 	
Length	DIN EN 558 - 1 series FTF 1 (DIN 3202 - series F 1)			
Actuator	Lever, optional pneumatic or electric actuator			
Accessories	Limit switches, solenoid valves, stem extensions			
ATEX-approval	or on request			

*) Special version: CSM, NBR, FKM-F, FEP / Parofluor on request

¹⁾ Working temperatures for sealing materials:

EPDM: -20 up to 90 °C
 NBR: -20 up to 100 °C
 FKM / FKM-F: -8 up to 100 °C

Example for an invitation to tender text:

Ball valve type 21, DN 50, PN 16, PVC-U / EPDM, flange connection acc. to DIN EN 1092-1 - PN 10/16, length acc. to DIN EN 558-1, series FTF 1, top flange acc. to DIN EN ISO 5211 for actuator assembly, integrated bottom stand

Document: FRANK_DB_L4_Kugelhahn Typ 21_04-2012_EN

Ball valve type 21

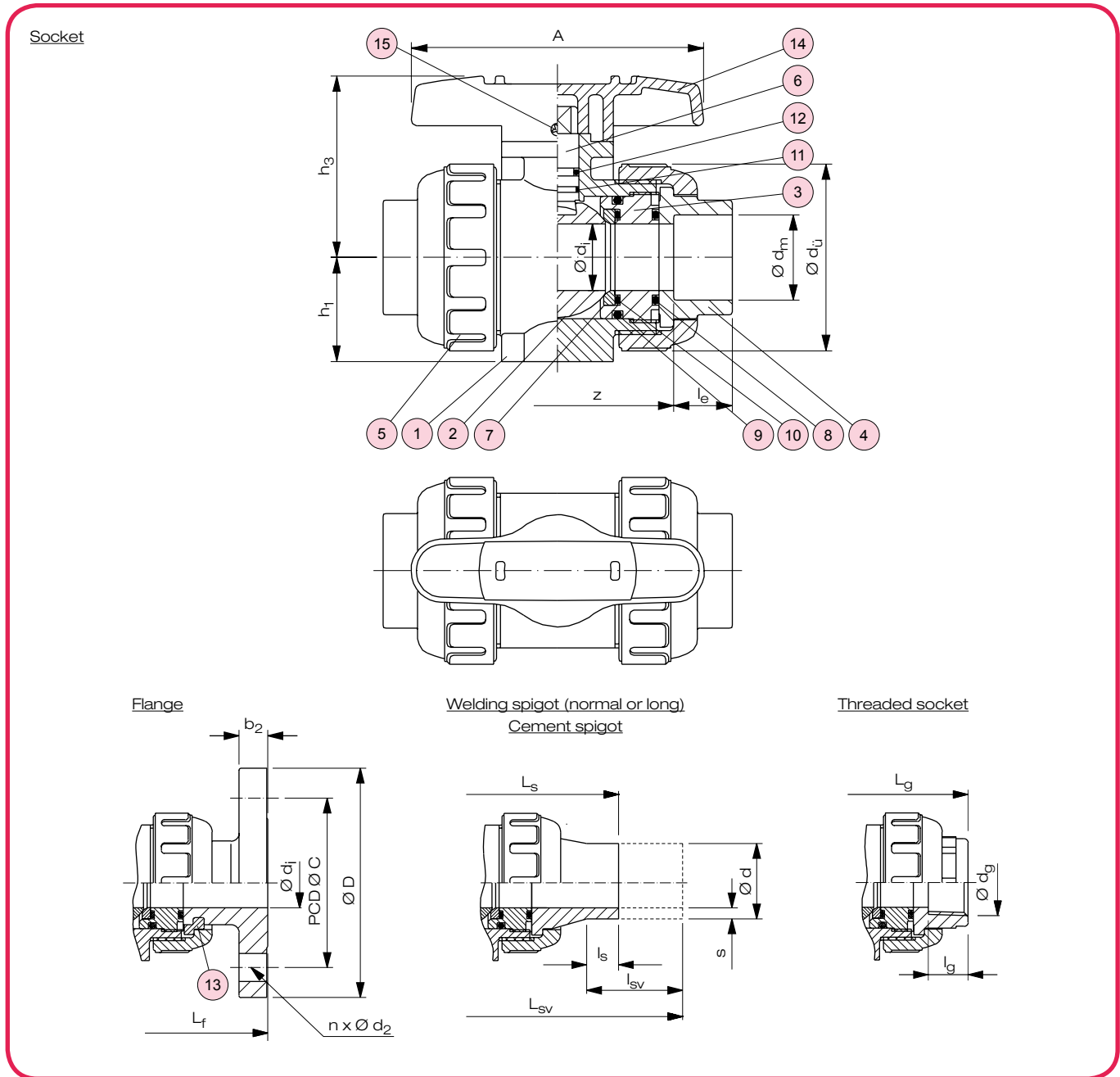

No.	Description	Number	Material
1	Body	1	PVC-U, PVC-C, PP, PVDF
2	Ball ^{*)}	1	PVC-U, PVC-C, PP, PVDF
3	Carrier	1 ¹⁾	PVC-U, PVC-C, PP, PVDF
4	End connector (socket, spigot, flange)	2	PVC-U, PVC-C, PE, PP, PVDF
5	Union nut	2	PVC-U, PVC-C, PP-G, PVDF
6	Stem ^{*)}	1	PVC-U, PVC-C, PP, PVDF
7	Ball seat ^{*)}	2	PTFE

No.	Description	Number	Material
8	O-ring (A) ^{*)}	2	EPDM, FKM ²⁾
9	O-ring (B) ^{*)}	1 ¹⁾	EPDM, FKM ²⁾
10	O-ring (C) / flat seat ^{*,3)}	2	EPDM, FKM ²⁾
11	O-ring (D) ^{*)}	1	EPDM, FKM ²⁾
12	O-ring (E) ^{*)}	1	EPDM, FKM ²⁾
13	Stop ring ⁴⁾	2	PVDF
14	Hand lever ⁵⁾	1	ABS
15	Screw ⁶⁾	1	A2 - 1.4301 (SUS 304)

^{*)} Wearing parts
¹⁾ DN 65 up to DN 100: 2 pieces
²⁾ Special version: CSM, NBR, FKM-F, FEP / Parofluor on request

³⁾ Flat seat for DN 65 and above ⁶⁾ DN 65 and above
⁴⁾ with flanged version only
⁵⁾ Special version: locking device

Ball valve type 21

Dimensions and weights - flange connection

Dimensions in mm											Weight in kg / pc.			
DN	d _i	d _ü	C	D	L _f	h ₁	h ₃	A	b ₂	n x d ₂	PVC-U	PVC-C	PP	PVDF
10	13	46	60	90	120	-	43,5	80	12,5	4 x 14	0,32	0,35	0,21	0,40
15	15	48	65	95	130	29	51,5	92	12,5	4 x 14	0,40	0,44	0,26	0,50
20	20	60	75	105	150	35	59,5	100	14,5	4 x 14	0,60	0,65	0,38	0,74
25	25	70	85	115	160	39	68	110	14,5	4 x 14	0,79	0,85	0,51	0,97
32	31	82	100	140	180	47	80,5	121	16,5	4 x 18	1,23	1,33	0,79	1,52
40	40	100	110	150	200	55	89	131	16,5	4 x 18	1,65	1,78	1,06	2,03
50	51	126	125	165	230	66	102,5	159	16,5	4 x 18	2,46	2,70	1,58	3,70
65	58	133	145	185	290	72	126	200	18	4 x 18	3,30	3,50	2,10	4,00
80	68,5	152	160	200	310	85	140	240	21	8 x 18	4,60	5,40	3,00	5,70
100	90	210	180	220	350	110	178	300	18	8 x 18	9,80	10,60	6,30	12,10

Dimensions and weights - true union with spigot (butt welding or electric welding socket)

Dimensions in mm													Weight in kg / pc.			
DN	d	d _i	d _ü	s ³⁾ SDR 17	s ³⁾ SDR 11	l _{sv} ²⁾	l _s ¹⁾	L _{sv} ²⁾	L _s ¹⁾	h ₁	h ₃	A	PVC-U	PVC-C	PP	PVDF
15	20	15	48	-	1,9	64	30	239	167	29	51,5	92	0,18	0,19	0,12	0,23
20	25	20	60	-	2,3	61	25	244	168	35	59,5	100	0,27	0,29	0,19	0,36
25	32	25	70	-	2,9	61	25	253	175	39	68	110	0,39	0,42	0,27	0,51
32	40	31	82	-	3,7	67	24	289	185	47	80,5	121	0,61	0,66	0,41	0,78
40	50	40	100	3,0	4,6	69	22	295	199	55	89	131	0,95	1,02	0,63	1,20
50	63	51	126	3,8	5,8	78	20	360	212	66	102,5	159	1,67	1,80	1,09	2,09
65	75	58	133	4,5	6,8	89	18	384	232	72	126	200	2,10	2,25	1,48	2,70
80	90	68,5	152	5,4	8,2	101	40	451	325	85	140	240	3,10	3,30	2,38	4,30
100	110	90	210	6,6	10,0	115	38	516	352	110	178	300	8,90	9,80	5,70	10,10

1) Weld spigot (PE 100, PP-R, PVDF) 2) long weld spigots (PE 100, PP-R) for electric welding

3) PVDF-weld spigot SDR 33 / SDR 21 with differing wall thickness

Dimensions and weights - true union with cement socket / welding socket

Dimensions in mm													Weight in kg / pc.			
DN	d _i	d _ü	Cement socket			Welding socket			h ₁	h ₃	A	Cement socket		Welding socket		
			d _m	l _e	z	d _m	l _e	z				PVC-U	PVC-C	PP	PVDF	
10	13	46	16	14	71	15,5	13	71	-	43,5	80	0,14	0,16	0,09	0,18	
15	15	48	20	16	70	19,5	16	72	29	51,5	92	0,19	0,20	0,12	0,23	
20	20	60	25	19	82	24,5	18	77	35	59,5	100	0,29	0,32	0,19	0,34	
25	25	70	32	22	87	31,5	19	83	39	68	110	0,42	0,45	0,27	0,51	
32	31	82	40	26	98	39,45	22	93	47	80,5	121	0,64	0,69	0,41	0,79	
40	40	100	50	31	101	49,45	24	102	55	89	131	0,97	1,04	0,62	1,19	
50	51	126	63	38	121	62,5	27	124	66	102,5	159	1,66	1,79	1,06	2,04	
65	58	133	75	44	145	74,3	31	145	72	126	200	2,30	2,47	1,48	2,70	
80	68,5	152	90	51	180	89,2	35	177	85	140	240	3,80	4,10	2,38	4,40	
100	90	210	110	61	227	109,1	41	230	110	178	300	9,20	9,90	5,70	10,80	

Dimensions and weights - true union with threaded socket / cement spigot

Dimensions in mm													Weight in kg / pc.				
DN	d _i	d _ü	Threaded socket			Cement spigot			h ₁	h ₃	A	Threaded socket				Cement spigot	
			d _g	l _g	L _g	d	l _s	L _s				PVC-U	PVC-C	PP	PVDF	PVC-U	
10	13	46	R 3/8"	15	99	16	16	114	-	43,5	80	0,15	0,17	0,10	0,19	0,14	
15	15	48	R 1/2"	15	102	20	18,5	124	29	51,5	92	0,20	0,21	0,13	0,24	0,19	
20	20	60	R 3/4"	17	120	25	24	144	35	59,5	100	0,31	0,33	0,20	0,37	0,29	
25	25	70	R 1"	20	131	32	24,5	154	39	68	110	0,43	0,46	0,27	0,52	0,42	
32	31	82	R 1 1/4"	22	150	40	28	174	47	80,5	121	0,69	0,74	0,44	0,84	0,64	
40	40	100	R 1 1/2"	25	163	50	34	194	55	89	131	1,06	1,15	0,68	1,30	0,97	
50	51	126	R 2"	28	197	63	38	224	66	102,5	159	1,83	1,97	1,17	2,24	1,66	
65	58	133	-	-	-	75	44	284	72	126	200	-	-	-	-	2,30	
80	68,5	152	-	-	-	90	51	300	85	140	240	-	-	-	-	3,40	
100	90	60	-	-	-	110	61	384	110	178	300	-	-	-	-	10,00	

Ball valve type 21

Top flange dimensions (DIN EN ISO 5211)
for actuator assembly

DN	Type	C ₁	D ₂	D ₃	D ₄	e	H ₂	H ₃	H ₄	H ₅	S	d ₄	e ₁
15	F03	36	42	25	13,5	5,5	30	6	3	8	10,5	7,3	19
20	F03	36	42	25	15	5,5	36,5	6	3	10	11	7,3	19
25	F03	36	42	25	15	5,5	43,5	6	3	10	11	7,3	19
32	F04	42	48	30	19	5,5	52,5	8	3	10	15	9	30
40	F05	50	57	35	23	6,5	61	10	3	12	18	9	30
50	F05	50	57	35	23	6,5	72,5	10	3	12	18	9	30
65	F07	70	81	55	30	9	85	13	3	16	24	9	48
80	F07	70	81	55	30	9	94	13	3	19	24	11	55
100	F10	102	116	70	40	11	126	16	3	23	34	11	65

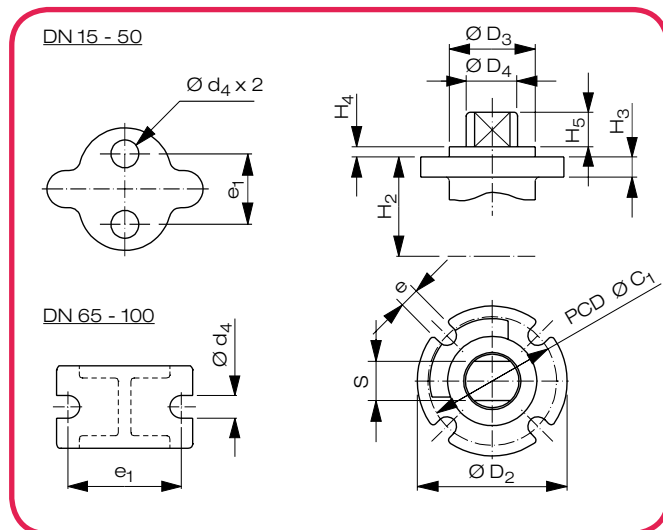

Flow rate characteristic value¹⁾ k_{VS} in m³/h

DN	10	15	20	25	32	40	50	65	80	100
k_{VS} [m ³ /h]	6,7	12,0	24,9	40,3	62,4	125,7	156,9	320,0	430,0	720,0

¹⁾ Definition k_{VS} -value see chapter T2 / technical information

Drive torque²⁾ M_A in Nm for ball movement

DN	10	15	20	25	32	40	50	65	80	100
M_A [Nm]	1,6	2,0	2,5	3,2	5,6	8,0	10,0	22,0	40,0	80,0

²⁾ all values refer to the maximum differential pressure

Vacuum resistance³⁾ in bar

DN	10 - 100
PVC-U, PVC-C, PP, PVDF	1,0

³⁾ all values refer to the range of allowed working pressures

Working pressure⁴⁾ p_B in bar

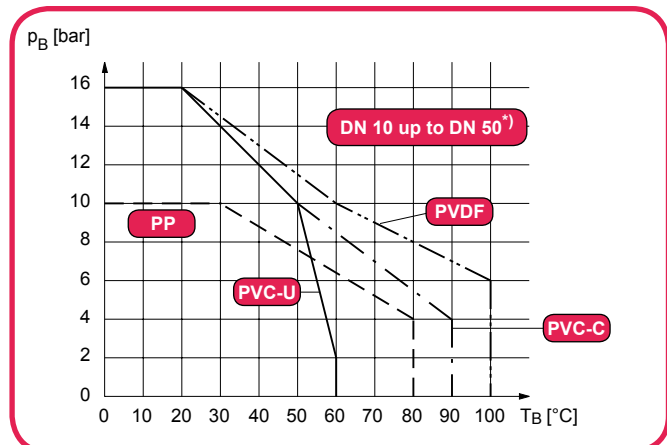

⁴⁾ Differing values for DN 65 up to DN 100 see opposite table

Body material	T_B in °C	DN			
		10 - 50	65	80	100
PVC-U	0 up to 20	16	16	16	10
	50	10	10	10	10
	60	2	-	-	-
PVC-C	0 up to 20	16	16	16	10
	50	10	10	10	10
	90	4	4	3	3
PP	-20 up to 30	10	10	10	10
	60	6	5	5	5
	80	4	3	3	3
PVDF	-20 up to 60	16	16	16	10
	80	10	10	10	10
	90	8	8	7	7
	100	6	6	5	5

⁴⁾ Definition see chapter T2 / technical information

Hydrostatic bursting pressure⁵⁾ in bar for PVC-U at 22 °C

DN	10	15	20	25	32	40	50	65	80	100
PVC-U	148	122	123	130	120	100	92	70	60	55

⁵⁾ Definition see chapter T2 / technical information

Ball valve type 21

Pressure loss diagramm

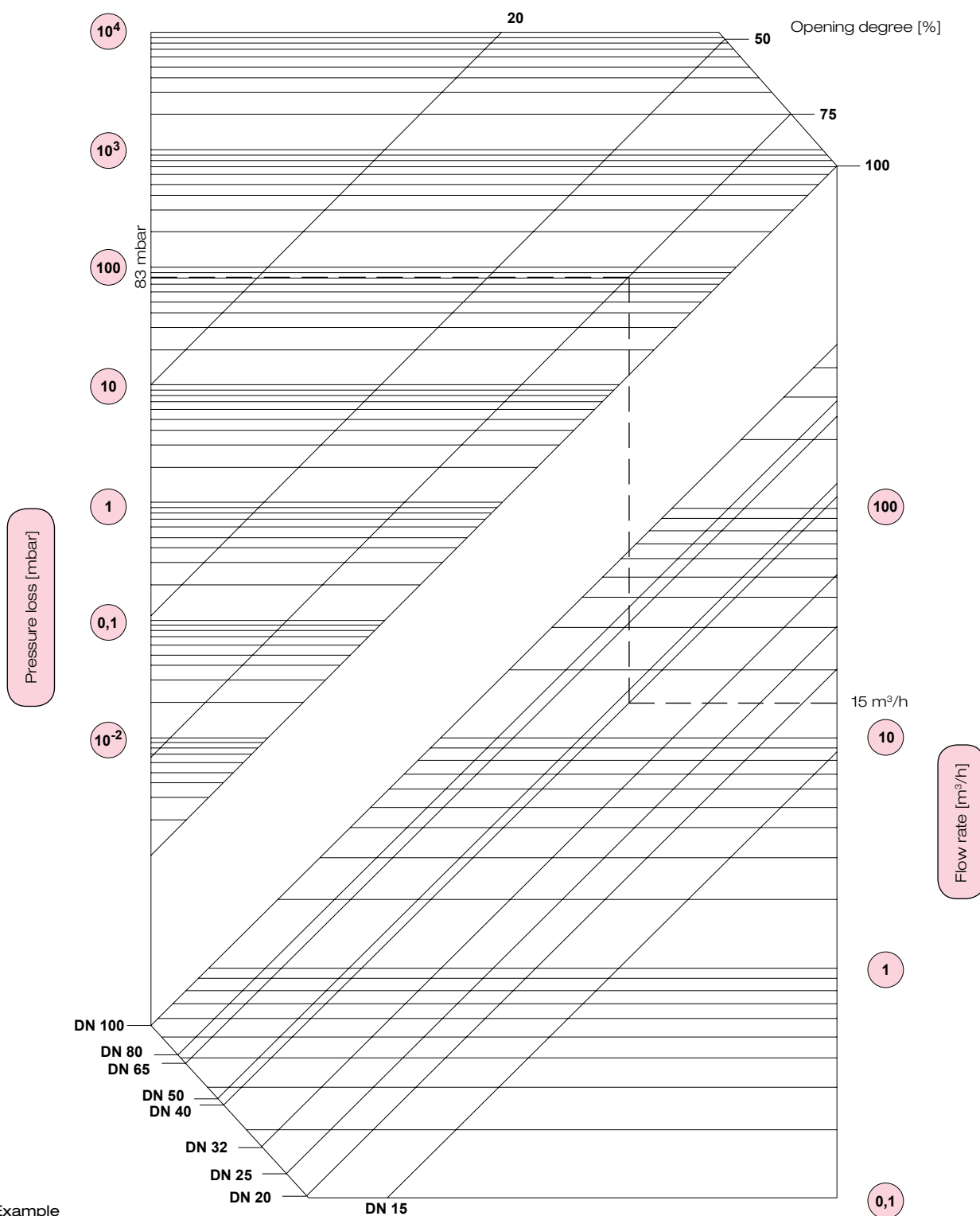

Example

Flow: 15 m³/h
 Nominal size: 40 mm
 Opening degree: 75 %
 Pressure loss: 83 mbar

Ball valve type 21

Maintenance and assembly instructions

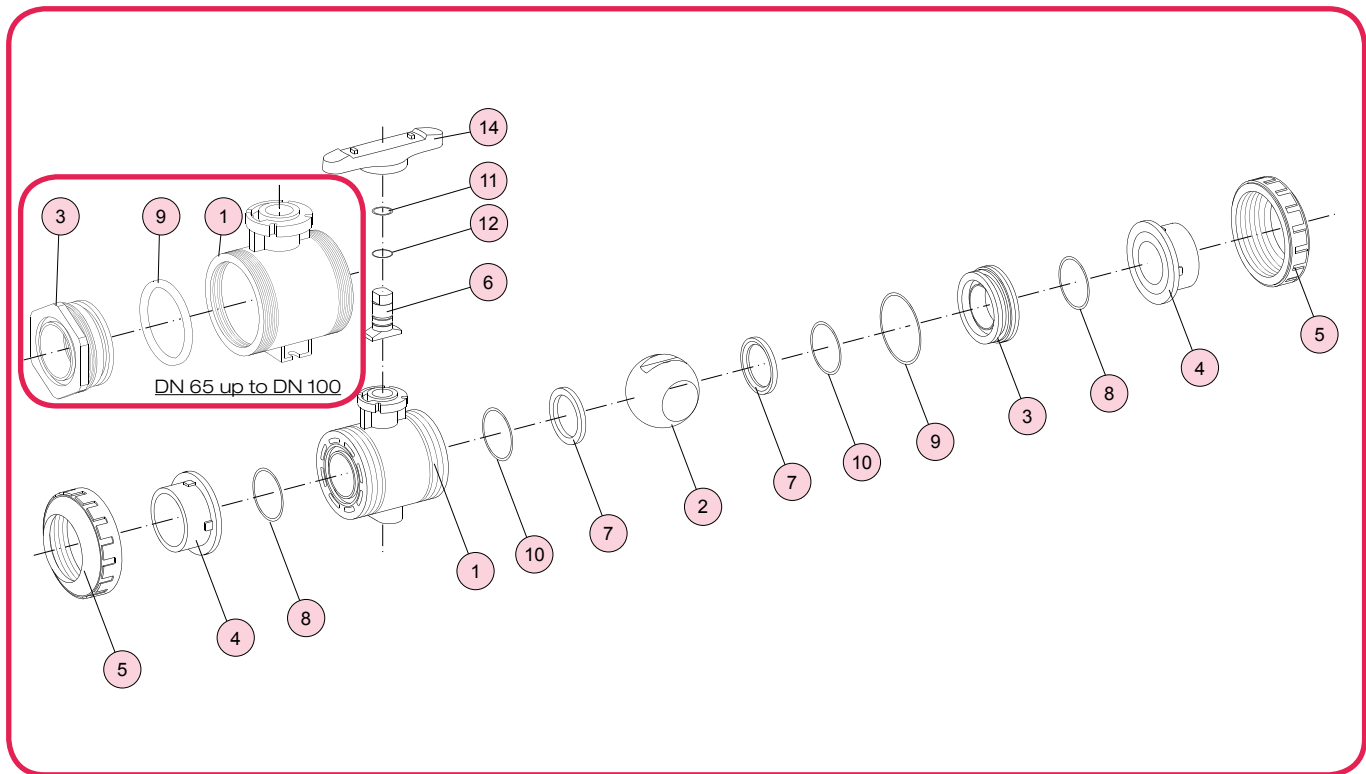

all sizes

Disassembly of the valve

Attention: Never dismantle the valve when the pipe is under pressure.

- Bring the valve in closed position. (Handle has to be in perpendicular position to pipe.)
- **Caution:** The union nuts have to be loosened and tightened by hand or by a strap wrench. Handling by force has to be avoided.
- Loosen the union nuts 5, disconnect the joints and remove the body part from the pipe.
- DN 65 to DN 100: Loosen the handle screw 15.
- Pull the handle 14 off the stem 6. Set the handle with its cams into the carrier 3 and turn it counter-clockwise off the body 1.
DN 65 and above: Proceed with the second carrier.
- Push the ball 2 carefully out of the body 1.
- Push the stem 6 from the top side into the body 1 and take it out of the body.
- Take the ball seats 7 and the o-ring 10 out of the body.

Assembly of the valve

- The valve assembly is to be performed in reverse order to the disassembly.
- Before the assembly all parts have to be checked for damages.
- All parts have to be clean.
- It is important that the carriers 3 are mounted carefully

into the body 1 and are tightened continuously with reasonable force. It is important that the o-ring 8 protrudes 1 mm from the body.

Caution: In activity the valve can be damaged when the carriers are mounted unevenly.

- If necessary, apply a silicone free lubricant on the o-rings.
- Before mounting the union nuts 5 check if the handle works smoothly. If necessary, loosen or adjust the carriers 3 to achieve smooth operation.
- After assembly carry out a pressure test acc. to DIN EN 12266-1.

Actuator assembly

- Take the handle 14 from the body 1.
DN 65 and above: Remove the handle screw 15 before.
- Mount the actuator and its assembly kit acc. to DIN/ISO 5211 onto the top flange.

Notes for correct installation

- The valve must be installed stress-free in the pipe (plane parallelism, axial, overall length).
- Tighten the connecting screws evenly and crosswise (observe tightening torques). In general, use washers for the nuts and bolts in plastic flanges.
- Socket and spigot type:
Gluing and welding have to be carried out according to the relevant standards (e.g. DVS).