

Diaphragm valve type 15 and type 72



Body material	PVC-U	PP	PVDF
Material of diaphragm	• EPDM	• CSM	• PTFE with EPDM cushion
Working temperature ¹⁾	0 °C up to 60 °C ²⁾	-20 °C up to 90 °C ²⁾	-40 °C up to 120 °C ²⁾
Nominal size	• Type 15: DN 125 and DN 150		• Type 72: DN 200 and DN 250
Connection with pipe	• Flange connection acc. to DIN EN 1092-1 (replaces DIN 2501) - PN 10 ³⁾		
Length	• DIN EN 558 - 1 series FTF 1 (DIN 3202 - series F 1)		
Actuator	Handwheel, optionally pneumatic or electric actuator		
Accessories	Limit switches		

¹⁾ Designed for 10 years of use with a neutral medium (water)

³⁾ Flange connection also acc. to ANSI available

²⁾ Working temperatures for diaphragm materials:

CSM: -20 up to 80 °C

EPDM: -40 up to 90 °C

PTFE: -40 up to 120 °C

Example for an invitation to tender text:

Diaphragm valve type 15, DN 125, PN 7, PVC-U / PTFE, flange connection acc. to DIN EN 1092-1 - PN 10, length acc. to DIN EN 558-1 series FTF 1, optical position indicator, adjustable stopper

Document: FRANK_DB_L1_Membranventil Typ 15 und Typ 72_04-2012_EN

Diaphragm valve type 15 and type 72

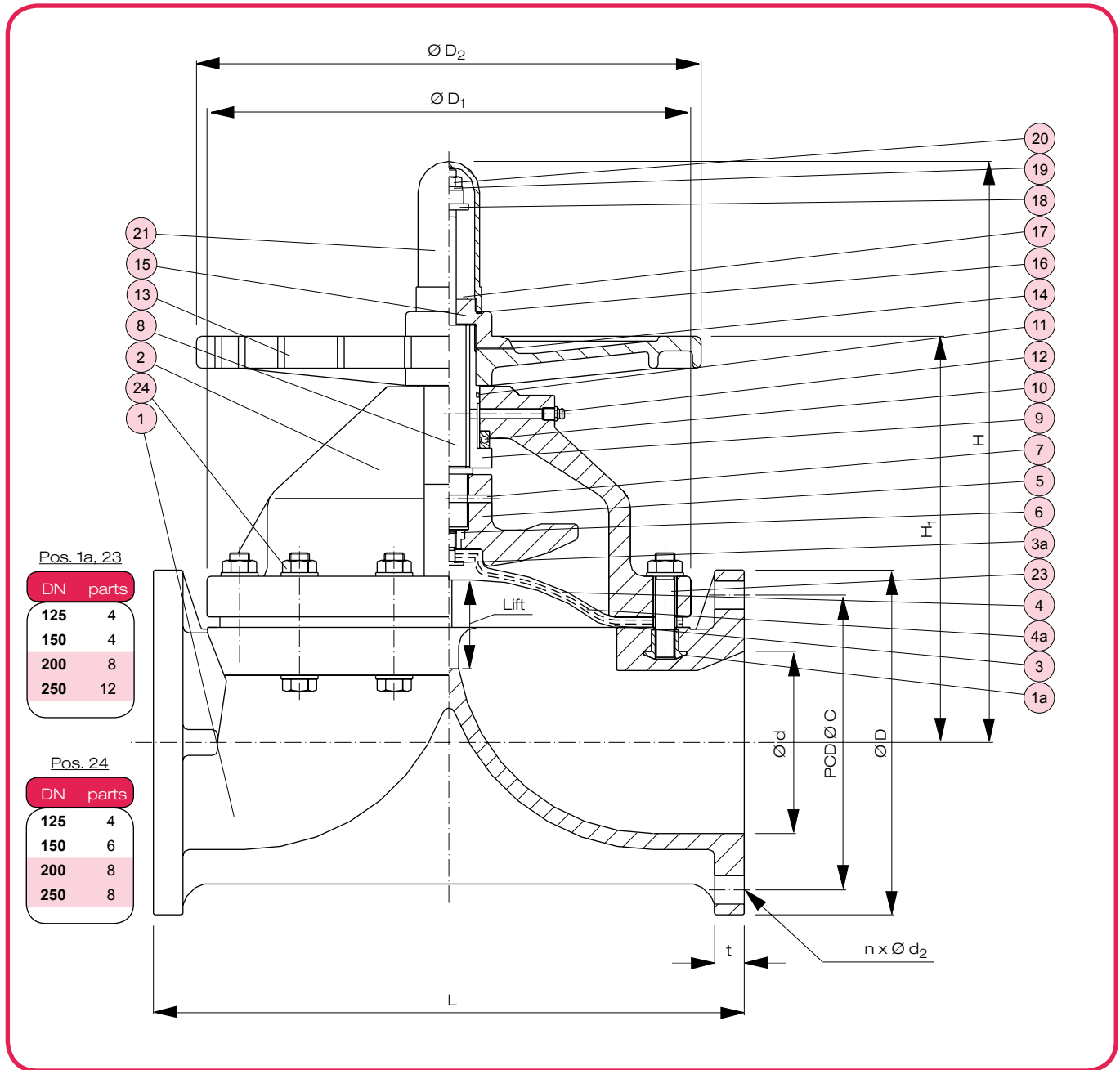

Pos. 1a, 23

DN	parts
125	4
150	4
200	8
250	12

Pos. 24

DN	parts
125	4
150	6
200	8
250	8

No.	Description	Number	Material
1	Base body	1	PVC-U/PVC-U, PP/PP, PVDF/PP-G, PVDF/PVDF
2	Bonnet	1	
1a	Thread insert	see above	Brass CW615N (C 3604) ¹⁾
3	Diaphragm ^{*,2)}	1	EPDM, CSM, PTFE ^{**)}
3a	Inserted metal	1	A2 - 1.4301 (SUS 304)
4	Cushion ³⁾	1	EPDM
4a	Diffusion stop inlay	1	PVDF ⁴⁾
5	Compressor	1	0.6020 (FC 20) ⁵⁾
6	Compressor nut	1	Brass CW615N (C 3604)
7	Compressor pin	1	A2 - 1.4301 (SUS 304)
8	Stem	1	Brass CW615N (C 3604)
9	Sleeve	1	Brass CW615N (C 3604)
10	Thrust ring	1	1.1133 (SUJ 2)

^{*)} Wearing parts

^{**)} with EPDM cushion

¹⁾ PVDF: material A2 - 1.4301 (SUS 304)

²⁾ with pin of A2 - 1.4301 (SUS 304)

No.	Description	Number	Material
11	O-ring (A)	1	NBR
12	Grease nipple	1	Brass CW615N (C 3604)
13	Handwheel	1	PP
14	Name plate	1	PVC
15	Cap	1	PP
16	Seat gasket (A)	1	EPDM
17	Seat ring	1	A2 - 1.4301 (SUS 304)
18	Stopper	1	1.0050 (SS 490)
19	Spring ring	1	A2 - 1.4301 (SUS 304)
20	Set nut	1	A2 - 1.4301 (SUS 304)
21	Gage cover	1	PC
23	Stud bolt, nut, washer	see above	A2 - 1.4301 (SUS 304)
24	Bolt, nut, washer	see above	A2 - 1.4301 (SUS 304)

³⁾ with PTFE-diaphragm only

⁴⁾ Optional for PTFE-diaphragm

⁵⁾ DN 125 and DN 150: PVDF

Diaphragm valve type 15 and type 72

Dimension and weights

Dimension in mm										Weight in kg / pc.					
DN	d	C	D	D ₁	D ₂	L	H	H ₁	t		Lift	n x d ₂	PVC-U	PP	PVDF
									PVC-U	PP, PVDF					
125	125	210	250	320	300	400	420	308	22	23	60	8 x 18	22,0	19,5	26,5
150	148	240	285	385	410	480	476	334	24	27	70	8 x 22	34,7	30,5	40,5
200	196	295	340	430	410	600	627	419	30	34	95	8 x 22	52,5	45,0	62,5
250	247	350	395	540	560	730	778	510	34	36	128	12 x 22	93,5	77,5	110,0

Drive torque¹⁾ M_A in Nm for stem movement

DN	rot. / lift	M _A A ²⁾	M _A B ³⁾
125	12	40	90
150	14	55	120
200	19	55	130
250	25	130	230

1) Referring to maximum working pressure

2) Elastomer diaphragm

3) PTFE-diaphragm

Flow rate characteristic value⁴⁾ k_{VS} in m³/h

DN	Lift of stem			
	25 %	50 %	75 %	100 %
125	117,95	207,69	243,59	256,41
150	157,26	276,92	324,79	341,88
200	275,21	484,62	568,38	598,29
250	393,16	692,31	811,97	854,70

4) Definition k_{VS}-value see chapter T2 / technical information

Vacuum resistance⁵⁾ in bar⁶⁾

DN	Version I	Version II
125	0,507	0,507
150	0,507	0,507
200	0,133	0,253
250	0,067	0,253

5) Referring to maximum working temperature

6) 1,0 atm = 1013,25 hPa = 1,01325 bar

Versions (to be specified by order):

I = standard, with elastomer diaphragm (EPDM or CSM)

II = standard, with PTFE-diaphragm

Hydrostatic bursting pressure⁷⁾ in bar for PVC-U at 20 °C

DN	125	150	200	250
PVC-U	65	60	50	40

7) Referring to maximum working temperature

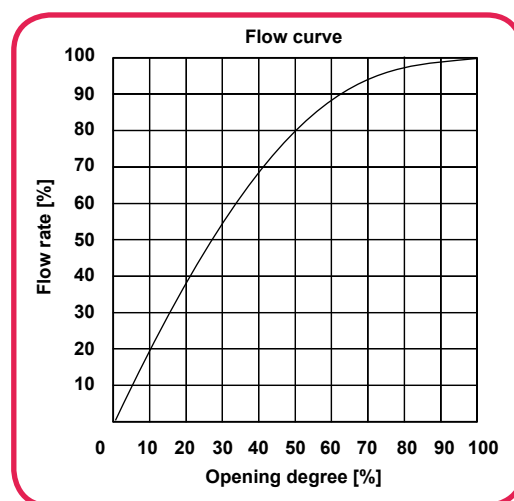

Diaphragm valve type 15 and type 72

Working pressure¹⁾ p_B in bar

Material			Working- temperature °C ²⁾	DN				DN, spec. B ³⁾	
Body	Bonnet	Diaphragm		125	150	200	250	200	250
PVC-U	PVC-U	PTFE	0 up to 40 60	7 6	5 4	4 3	4 3	- -	- -
		EPDM, CSM	0 up to 40 60	8 7	8 5	5 4	4,5 3,5	- -	- -
PP	PP	PTFE	-20 up to 40 60	7 5,8	5 4,1	4 3	4 3	- -	- -
			90	4	3	2	2	-	-
		EPDM, CSM	-20 up to 40 60	8 6,8	8 6,3	5 4	4,5 3,5	- -	- -
			90	5	4	2,5	2,5	-	-
PVDF	PP-G (PVDF)	PTFE	-40 up to 60 80	7 6	5 4,2	4 3	4 3	4 3	4 3
			100	5	3,6	2,5	2,5	3	3
			120	4	3	2	2	3	3

¹⁾ Designed for 10 years of use with a neutral medium (water)

²⁾ Working temperatures of diaphragm materials:

CSM: -20 up to 80 °C

EPDM: -40 up to 90 °C

PTFE: -40 up to 120 °C

³⁾ Specification B: version with u-bolts

Tightening torque $M_{d_{min/max}}$ in Nm
for bonnet bolts

DN	Elastomer-diaphragm • EPDM • CSM		PTFE-diaphragm with EPDM-cushion	
	$M_{d_{min}}$	$M_{d_{max}}$	$M_{d_{min}}$	$M_{d_{max}}$
125	20	25	25	30
150	25	30	26	33
200, 250	25	30	28	33

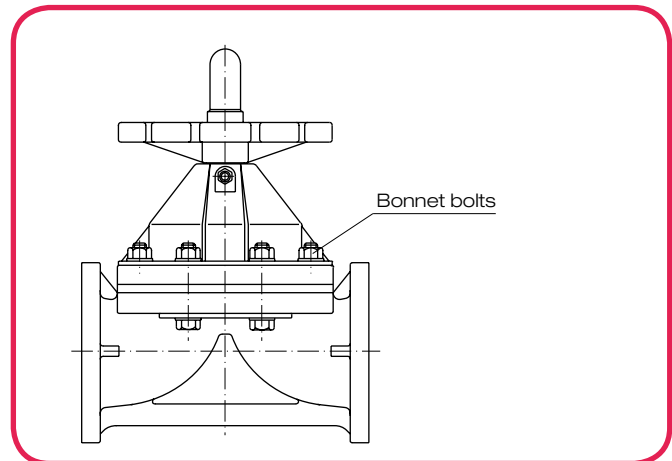

Diaphragm valve type 15 and type 72

Pressure loss diagram

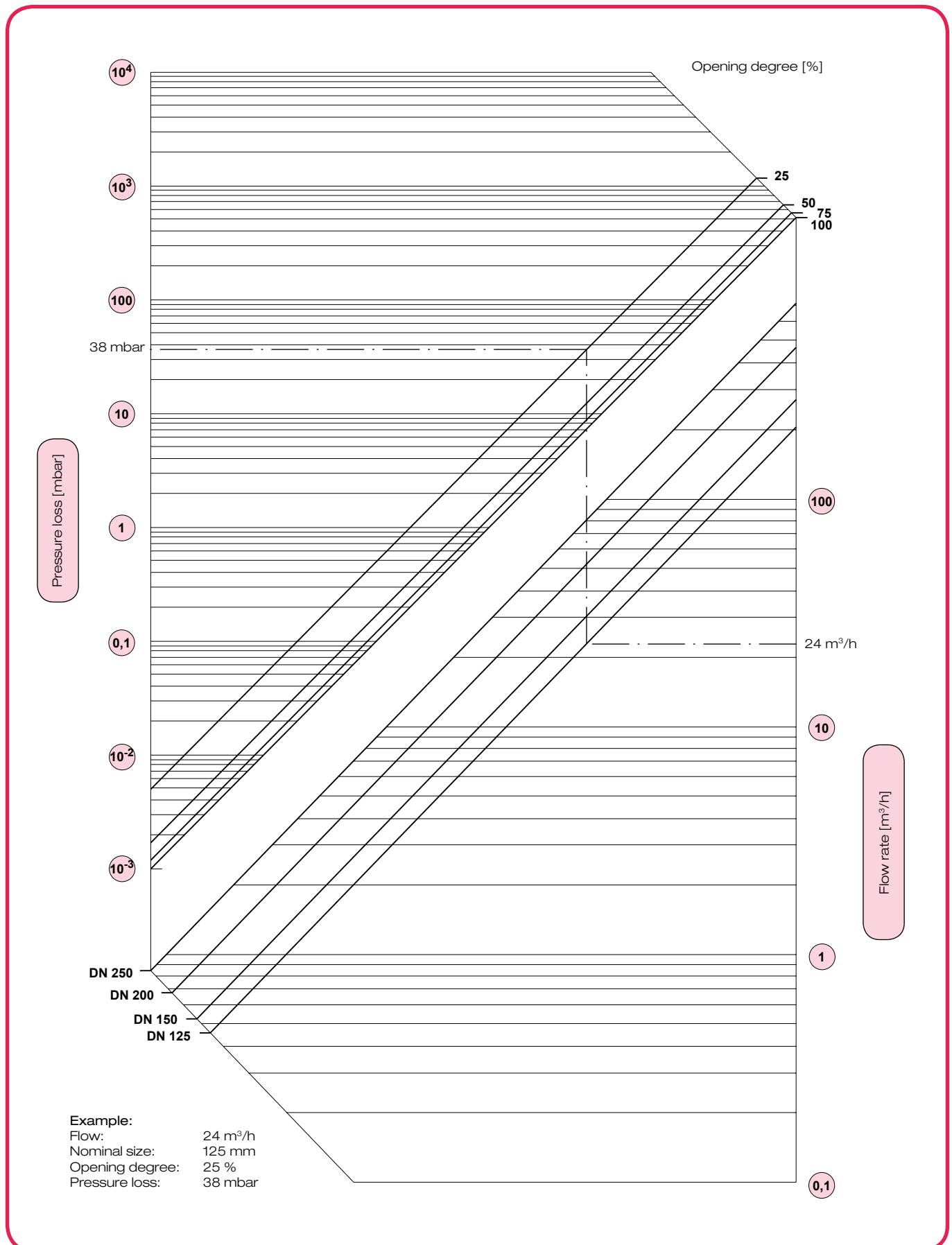

Diaphragm valve type 15 and type 72

Maintenance and installation

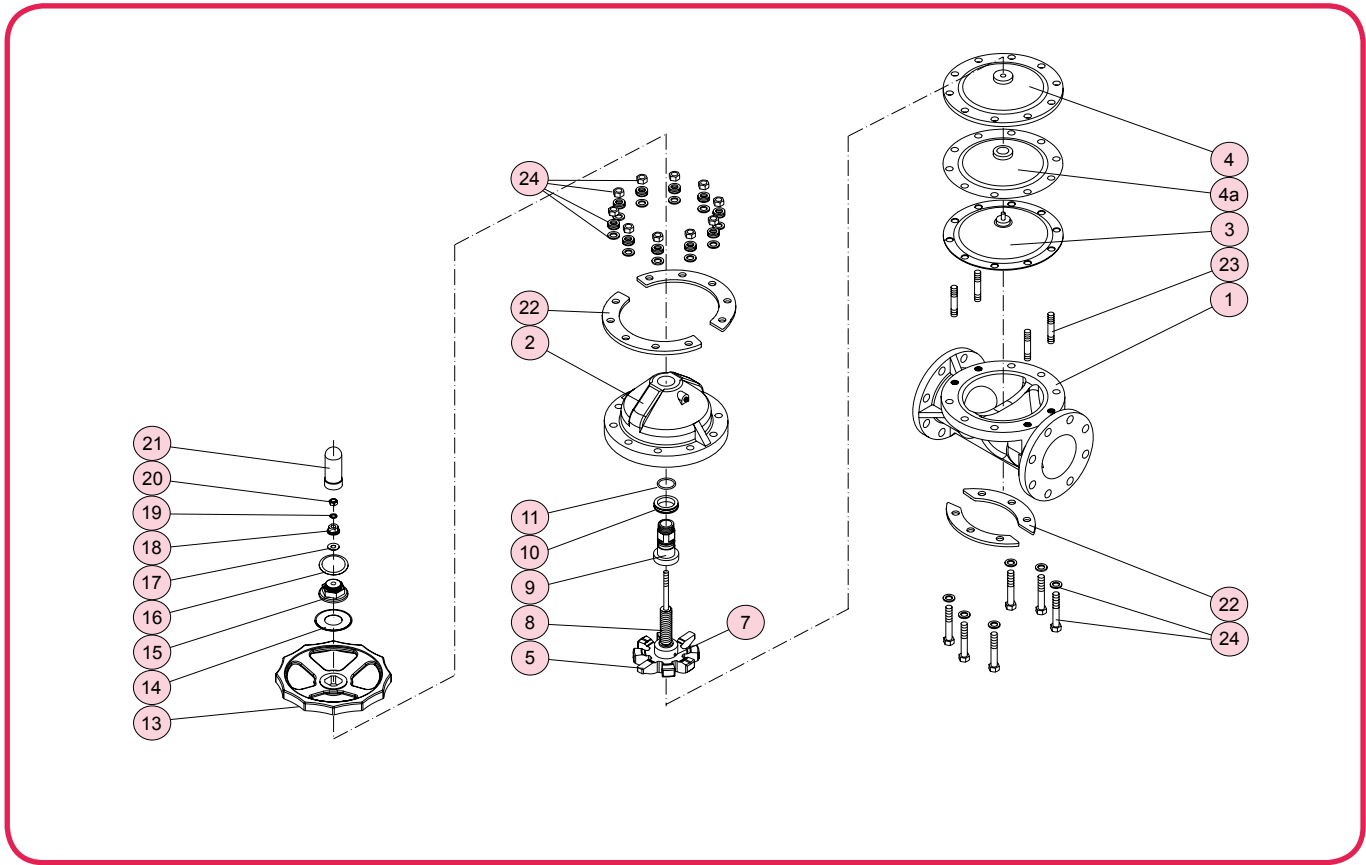

all DN

Required tools:

DN	Spanner	Pin driver
125	2x19; 24; 51	6
150	2x19; 24; 59,5	6
200	2x24; 32; 30; 69	8
250	2x24; 32; 30; 69	8

Disassembly of the valve

Attention: Never dismantle the valve when the pipe is under pressure.

- Dismantle the valve from the pipe: remove flange bolts.
- Bring the valve in half opened position. Loosen the bonnet bolts 24 and remove the bonnet 2.
- Unscrew gauge cover 11 counter-clockwise.
- Turn the hand wheel 10 clockwise to the stopper then turn it back slightly.
- Turn the diaphragm 3 counter-clockwise and remove it from the compressor nut 6. Drive compressor pin 7 out of the compressor 5.
- Hold stopper 18 with a spanner and loosen set nut 20.
- Remove hand wheel 13 from sleeve 9 and remove sleeve from the spindle 8.
- Remove O-ring 11 and thrust ring 10 from sleeve 9.

Assembly of the valve

- The valve assembly is to be performed in reverse order to the disassembly.
- Before the assembly all parts have to be checked for damages.
- All parts have to be clean.
- Drive compressor pin 7 into compressor 5 so that it is flush with it.
- The diaphragm flag must be positioned in the clearances of body and bonnet.

Stopper adjustment

- Close the valve by turning the hand wheel 13 clockwise by hand. Check the diaphragm's position in the valve body. In closed position it must completely cover the nose piece of the body.
- Tighten the stopper 18 with medium force and hold it with a spanner to prevent it from turning. Tighten set nut 20.

Notes for correct installation

- The valve must be installed stress-free in the pipe (plane parallelism, axial, overall length).
- Tighten the connecting screws evenly and crosswise (observe tightening torques). In general, use washers for the nuts and bolts in plastic flanges.