

Diaphragm valve type 14



Body material	PVC-U	PVC-C	PP	PVDF
Material of diaphragm	• EPDM		• CSM	• PTFE with EPDM cushion
Working temperature ¹⁾	0 °C up to 60 °C ²⁾	0 °C up to 90 °C ²⁾	-20 °C up to 90 °C ²⁾	-40 °C up to 120 °C ²⁾
Nominal size	DN 15 up to DN 100			
Connection with pipe	• Flange connection acc. to DIN EN 1092-1 (replaces DIN 2501) - PN 10 ³⁾		• True union with -Cement- / welding socket -Spigot	-Threaded socket
Length	• DIN EN 558 - 1 series FTF 1 (DIN 3202 - series F 1)		• Company standard	
Actuator	Handwheel, optionally pneumatic or electric actuator			
Accessories	Limit switches			

¹⁾ Designed for 10 years of use with a neutral medium (water)

³⁾ Flange connection also acc. to ANSI available

²⁾ Working temperatures for diaphragm materials:

CSM: -20 up to 80 °C

EPDM: -40 up to 90 °C

PTFE: -40 up to 120 °C

Example for an invitation to tender text:

Diaphragm valve type 14, DN 50, PN 10, PVC-U / PTFE, flange connection acc. to DIN EN 1092-1 - PN 10, length acc. to DIN EN 558-1 series FTF 1, optical position indicator, adjustable stopper

Document: FRANK_DB_L1_Membranventil Typ 14_04-2012_EN

Diaphragm valve type 14

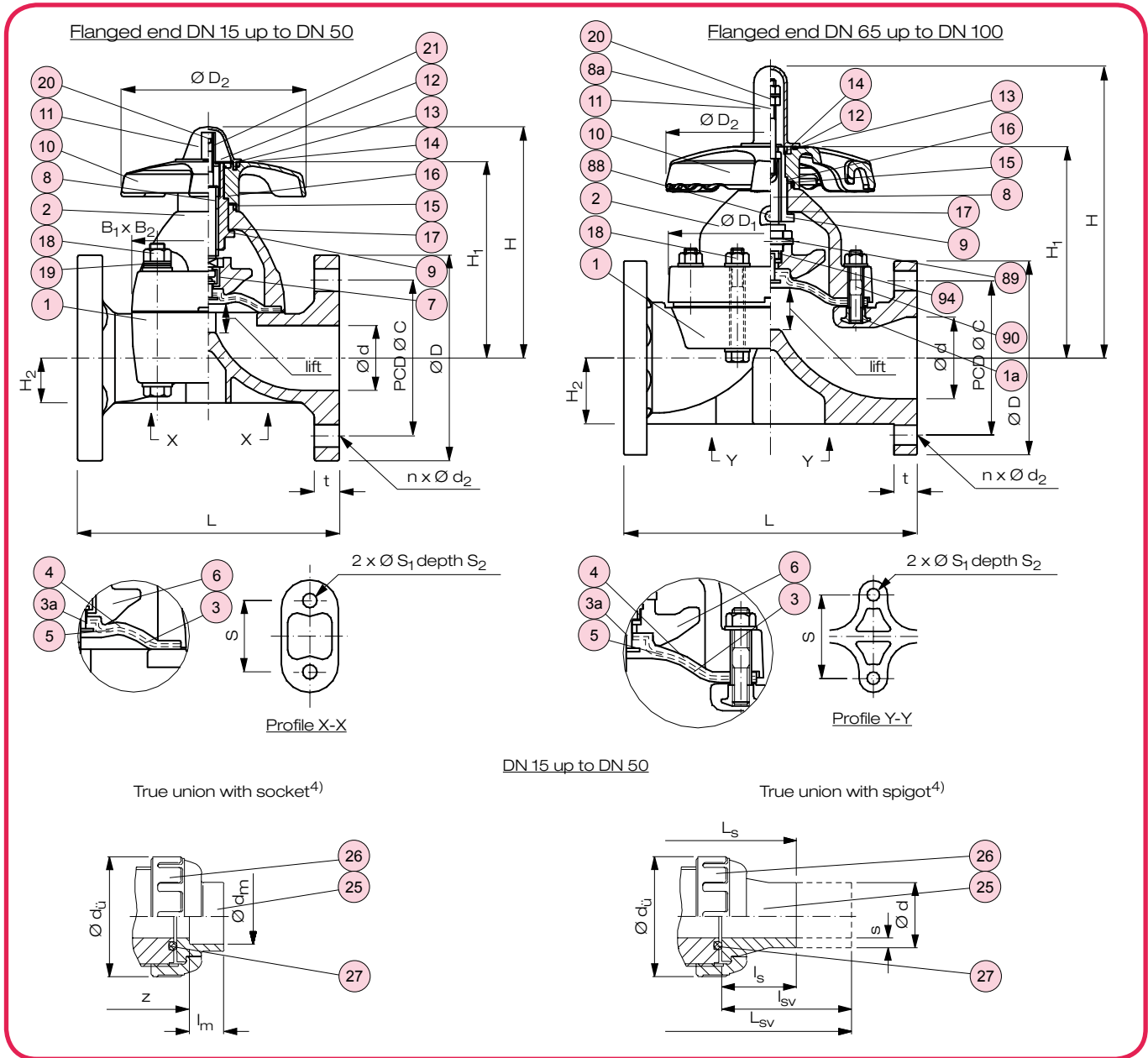

No.	Description	Number	Material
1	Base body	1	PVC/PVC, PVC-C/PP, PP/PP
2	Bonnet		
1a	Thread insert ¹⁾	1	Brass CW615N (C 3604)
3	Diaphragm ^{*,2)}	1	EPDM, CSM, PTFE ^{**)}
3a	Inserted metal of diaphragm	1	A2 - 1.4301 (SUS 304)
4	Cushion ³⁾	1	EPDM
5	Diffusion stop inlay	1	PVDF
6	Compressor	1	PVDF
7	Joint ⁴⁾	1	A2 - 1.4301 (SUS 304)
8	Stem	1	Brass C 3604
8a	Indicator rod	1	A2 - 1.4301 (SUS 304)
9	Sleeve	1	Brass CW615N (C 3604)
10	Hand wheel	1	PP
11	Gauge cover	1	PC
12	Name plate	1	PVC
13	Retaining ring	1	A2 - 1.4301 (SUS 304)
14	O-ring (A)	1	EPDM

No.	Description	Number	Material
15	O-ring (B)	1	EPDM
16	Thrust ring (A)	1	UHMWPE
17	Thrust ring (B)	1	UHMWPE
18	Bolt, nut, washer	4	A2 - 1.4301 (SUS 304)
19	Disk spring package ⁵⁾	4	A2 - 1.4301 (SUS 304)
20	Stopper	1	Brass C 3604 ⁴⁾ / 1.4301 ¹⁾
21	Screw ⁴⁾	1	A2 - 1.4301 (SUS 304)
25	End connector (spigot, socket) ⁴⁾	2	PVC-U/-C, PE 100, PP, PVDF
26	Union nut ⁴⁾	2	PVC-U/-C, PP-G, PVDF
27	O-ring ^{*,4)}	2	EPDM, FPM
88	Grease nipple ¹⁾	1	Brass CW615N (C 3604)
89	Compressor pin ¹⁾	1	A2 - 1.4301 (SUS 304)
90	Stud bolt, nut, washer ¹⁾	4	A2 - 1.4301 (SUS 304)
94	Inserted metal of diaphragm ¹⁾	1	A2 - 1.4301 (SUS 304)

^{*)} Wearing parts
^{**)} with EPDM cushion
¹⁾ DN 65 - DN 100 only
²⁾ with stainless steel pin
³⁾ with PTFE diaphragm only
⁴⁾ DN 15 - DN 50 only
⁵⁾ with PVDF body only

Diaphragm valve type 14

Dimensions and weights - flange connection

Dimensions in mm																	Weight in kg / pc.				
DN	d	C	D	B ₁	B ₂	D ₁	D ₂	L	H	H ₁	H ₂	t	S	S ₁	S ₂	Lift	n x d ₂	PVC-U	PVC-C	PP	PVDF
15	16	65	95	54	66	-	100	130	104	86	19,5	12	25	7	13	10	4 x 14	0,7	0,7	0,6	0,8
20	20	75	105	54	66	-	100	150	106	88	17,5	13	25	7	13	10	4 x 14	0,8	0,8	0,6	0,9
25	25	85	115	67	80	-	100	160	111	93	18,5	13	25	7	13	12	4 x 14	1,1	1,1	0,8	1,3
32	32	100	140	67	80	-	100	180	116	97	22,5	16	25	7	13	12	4 x 18	1,4	1,4	1,0	1,6
40	40	110	150	108	108	-	156	200	177	144	27,5	20	45	9	15	21	4 x 18	2,8	2,7	2,2	3,1
50	52	125	165	123	123	-	156	230	191	158	36	22	45	9	15	25	4 x 18	3,6	3,5	2,8	4,1
65	67	145	185	-	-	175	220	290	266	188	61	22	85	11	20	34	4 x 18	5,6	5,3	4,2	6,5
80	78	160	200	-	-	201	220	310	280	202	63	24	100	15	28	42	8 x 18	7,1	6,9	5,4	8,0
100	100	180	220	-	-	241	257	350	329	241	78	24 ¹⁾	120	15	28	50	8 x 18	10,5	8,9	8,7	11,7

¹⁾ PP-, PVDF-version = 26mm

Dimensions and weights - true union with cement / welding socket

Dimensions in mm														Weight in kg / pc.						
DN	d _Ü	z	PVC socket		PP, PVDF socket		B ₁	B ₂	D ₂	H	H ₁	H ₂	S	S ₁	S ₂	Lift	Socket			
			d _m	l _m	d _m	l _m											PVC-U	PVC-C	PP	PVDF
15	48	96	20	16	19,50	14,5	54	66	100	104	86	19,5	25	7	13	10	0,5	0,5	0,4	0,6
20	60	109	25	19	24,50	16,0	54	66	100	106	88	17,5	25	7	13	10	0,6	0,6	0,5	0,7
25	70	128	32	22	31,50	18,0	67	80	100	111	93	18,5	25	7	13	12	0,9	0,9	0,7	1,0
32	82	136	40	26	39,45	20,5	67	80	100	116	97	22,5	25	7	13	12	1,1	1,1	0,8	1,2
40	100	184	50	31	49,45	23,5	108	108	156	177	144	27,5	45	9	15	21	2,6	2,5	2,0	2,7
50	106	219	63	38	62,50	27,5	123	123	156	191	158	36	45	9	15	25	2,9	2,8	2,3	3,1

Dimensions and weights - true union with spigot (butt welding or electric welding socket)

Dimensions in mm																	Weight in kg / pc.					
DN	d	d _Ü	s ²⁾		l _S ³⁾	L _S ³⁾	l _{SV} ⁴⁾	L _{SV} ⁴⁾	B ₁	B ₂	D ₂	H	H ₁	H ₂	S	S ₁	S ₂	Lift	PVC-U	PVC-C	PP	PVDF
			SDR 17	SDR 11																		
15	20	48	-	1,9	51	188	87	246	54	66	100	104	86	19,5	25	7	13	10	0,5	0,5	0,4	0,6
20	25	60	-	2,3	49	198	87	272	54	66	100	106	88	17,5	25	7	13	10	0,6	0,6	0,5	0,7
25	32	70	-	2,9	49	217	88	295	67	80	100	111	93	18,5	25	7	13	12	0,9	0,9	0,7	1,0
32	40	82	-	3,7	49	222	101	320	67	80	100	116	97	22,5	25	7	13	12	1,1	1,1	0,8	1,2
40	50	100	3,0	4,6	52	268	100	372	108	108	156	177	144	27,5	45	9	15	21	2,6	2,5	2,0	2,7
50	63	106	3,8	5,8	48	301	122	449	123	123	156	191	158	36	45	9	15	25	2,9	2,8	2,3	3,1

²⁾ Spigot (PE 100, PP-R)

³⁾ Spigot, short (PE 100, PP-R, PVDF)

⁴⁾ Spigot, long (PE 100, PP-R)

Flow rate characteristic value⁵⁾ k_{VS} in m³/h

DN	Lift of stem			
	25 %	50 %	75 %	100 %
15	0,98	2,34	3,53	4,10
20	1,09	2,58	3,90	4,53
25	1,74	4,14	6,25	7,26
32	2,26	5,36	8,09	9,40
40	5,33	12,67	19,11	22,22
50	8,82	20,95	31,61	36,75
65	34,51	58,12	68,29	72,65
80	46,69	78,63	92,39	98,29
100	75,11	126,50	148,63	158,12

⁵⁾ Definition k_{VS}-value see chapter T2 / technical information

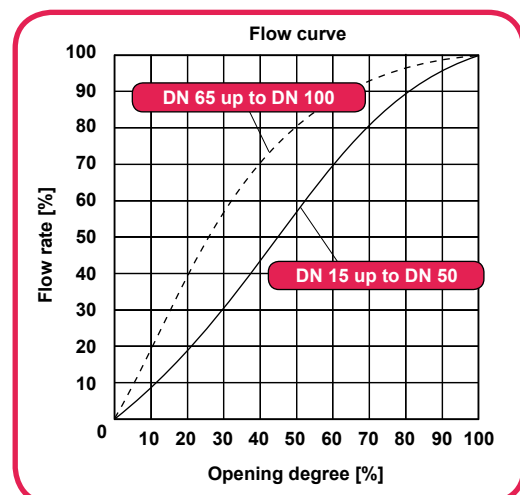

Diaphragm valve type 14

Tightening torque $M_{d_{min/max}}$ in Nm for bonnet bolts

DN	Elastomer-Diaphragm • EPDM • CSM		PTFE-diaphragm with EPDM cushion cover	
	$M_{d_{min}}$	$M_{d_{max}}$	$M_{d_{min}}$	$M_{d_{max}}$
15 - 20	3	5	5	7
25 - 32	5	7	8	10
40	12	14	15	17
50	15	17	20	23
65	13	15	15	17
80	18	20	20	22
100	35	38	40	43

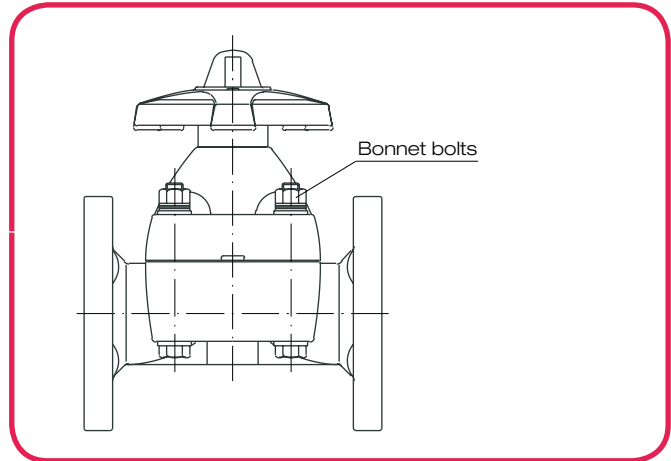

Drive torque¹⁾ M_A in Nm for stem movement

DN	rot. / lift	M_A A ²⁾	M_A B ³⁾
15	5	3	4
20	5	3	4
25	6	4	5
32	6	4	5
40	5	10	12
50	6	10	12
65	8	19	23
80	10	26	31
100	10	32	38

Hydrostatic bursting pressure⁴⁾ in bar⁵⁾

DN	20 °C (PVC-U)	50 °C (PVC-U)
15	165	178
20	184	153
25	175	130
32	177	160
40	155	125
50	133	108
65	103	85
80	108	65
100	84	75

1) Referring to maximum working pressure
 2) Elastomer diaphragm
 3) PTFE diaphragm

4) Definition see chapter T2 / technical information
 5) 1,0 atm = 1013,25 hPa = 1,01325 bar

Working pressure⁶⁾ p_B in bar

Body material	T_B in °C	DN 15 - 50		DN 15 - 50 TU ⁷⁾
		DN 15 - 50	DN 65 - 100	
PVC-U	0 up to 40	10	10	10
	50	8,5	9	9
	60	7	8	-
PVC-C	0 up to 40	10	10	10
	50	9	9,2	9
	60	8	8	8
	80	6	6,8	6
	90	3	6	3
PP	-20 up to 40	10	10	10
	60	8	8,4	8
	80	6	6,8	6
PVDF	90	5	6	-
	-40 up to 60	10	10	10 ⁸⁾
	80	8,3	8	8
	100	6,7	6	6
	120	5	5	-

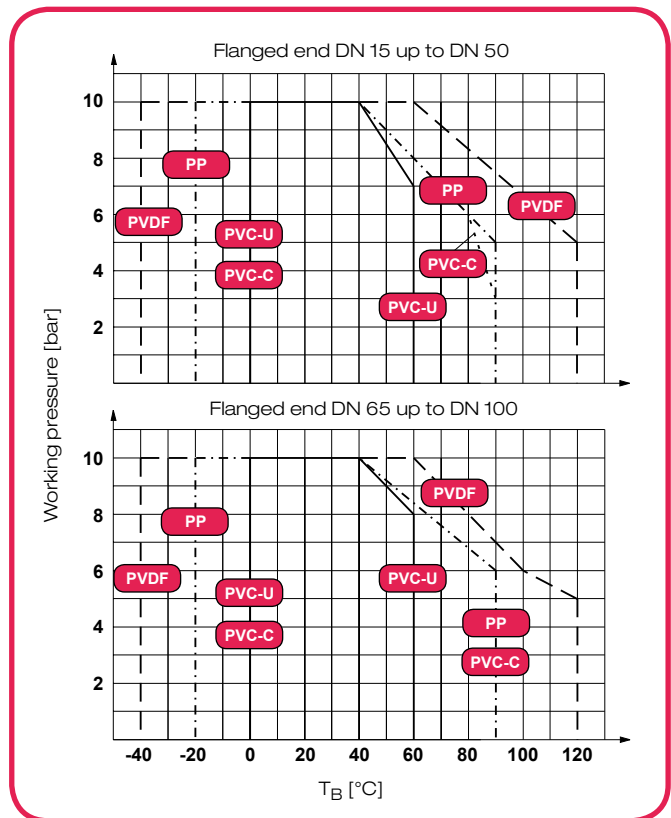

6) Definition see chapter T2 / technical information
 7) True Union
 8) -20 up to 60 °C

Vacuum resistance⁹⁾ in bar

DN	Vacuum resistance
15 - 50	1,0
65 - 100	0,5 ¹⁰⁾

9) Referring to maximum working temperature
 10) Special version with higher vacuum resistance: 1,0 bar on request

Diaphragm valve type 14

Pressure loss diagram for DN 15 up to DN 50

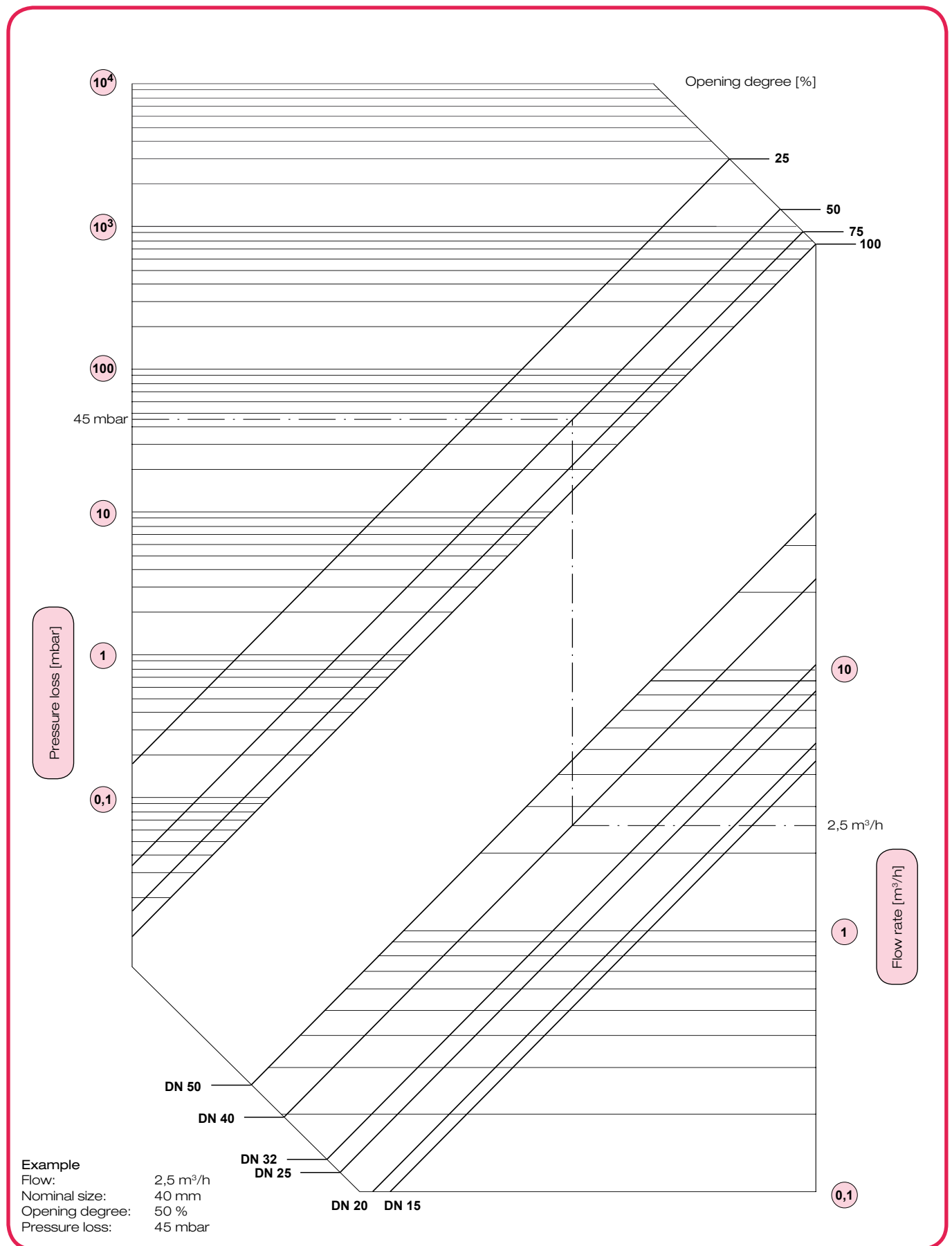

Diaphragm valve type 14

Pressure loss diagram for DN 65 up to DN 100

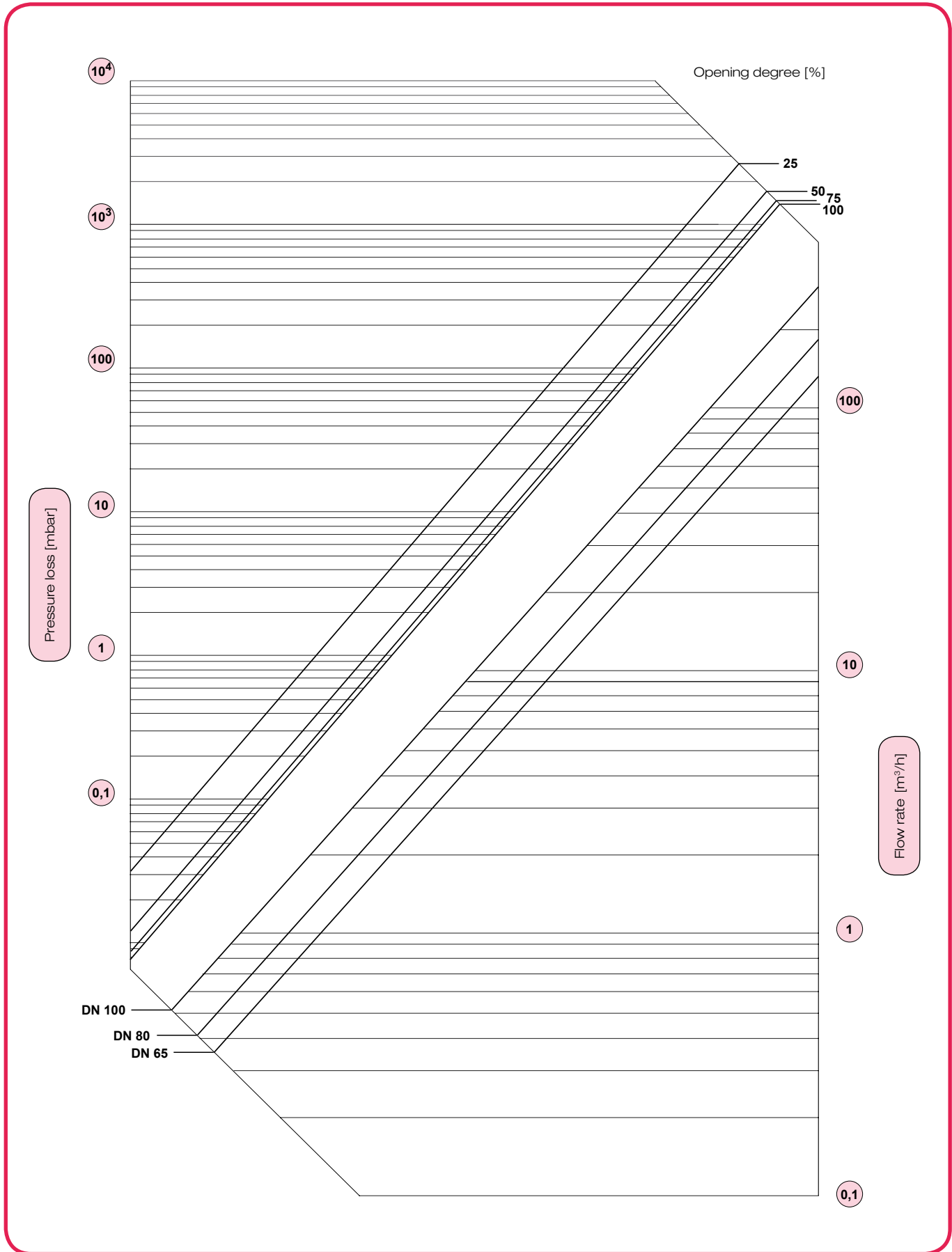

Diaphragm valve type 14

Maintenance and installation

DN 15-50			DN 65-100			
Required tools:			Required tools:			
DN	15-32	40, 50	DN	65	80	100
Allen key	3	4	Allen key	-	-	-
Spanner	8; 2x13	10; 2x19	Spanner	2x17	2x17; 19	2x17; 24
Circlip-pliers	19-60	19-60	Circlip-pliers	19-60	19-60	19-60
Pin driver	-	-	Pin driver	5	5	5
Disassembly of the valve						
<i>Attention: Never dismantle the valve when the pipe is under pressure.</i>						
<ul style="list-style-type: none"> ■ Dismantle the valve from the pipe (flanged version: remove flange bolts; true union version: remove union nut 26 (s. L1-2)). ■ Bring the valve in half opened position. Loosen the bonnet bolts 18 and remove the bonnet 2. 			alike DN 15-50			
<ul style="list-style-type: none"> ■ Remove gauge cover 11. 			<ul style="list-style-type: none"> ■ Unscrew gauge cover 11 counter-clockwise. 			
<ul style="list-style-type: none"> ■ Remove o-ring 14 and name plate 12. ■ Turn the hand wheel 10 clockwise to the stopper, then turn it back slightly. ■ Turn the diaphragm 3 of 90°, pull diaphragm 3 and compressor 6 off the stem 8. 			alike DN 15-50			
<ul style="list-style-type: none"> ■ Pull joint 7 off stem 8. ■ Hold stopper 20 with spanner to prevent it from turning and loosen screw 21 with an allen key. Unscrew the stopper from the stem. 			<ul style="list-style-type: none"> ■ Drive compressor pin 89 out of compressor 6, so that the compressor can be removed from stem 8. ■ Remove group of parts 20, consisting of stopper, red washer, nut and blank washer, from the stem. Loosen the nut first. 			
<ul style="list-style-type: none"> ■ Remove the retaining c-type ring 13 with the circlip-pliers from sleeve 9. ■ Pull the hand wheel 10 off the sleeve 9. ■ Remove the thrust rings 16 + 17 and o-ring 14 from the bonnet. 			alike DN 15-50			
Assembly of the valve						
<ul style="list-style-type: none"> ■ The valve assembly is to be performed in reverse order to the disassembly. ■ Before the assembly all parts have to be checked for damages. ■ All parts have to be clean. 						
<ul style="list-style-type: none"> ■ To mount the diaphragm, put the joint 7 on the stem 8. The slot must be in 90° position to the axle between the guiding slots in the inner side of bonnet 2. 			<ul style="list-style-type: none"> ■ To mount the diaphragm, put the compressor 6 on the stem 8. Drive pin 89 into compressor 6 so that it is flush with it. 			
<ul style="list-style-type: none"> ■ The diaphragm flag must be positioned in the clearances of body and bonnet. 						
Stopper adjustment						
<ul style="list-style-type: none"> ■ Close the valve by turning the hand wheel 10 clockwise by hand. Check the diaphragm's position in the valve body: In closed position it must completely cover the nose piece of the body. 			alike DN 15-50			
<ul style="list-style-type: none"> ■ Tighten the stopper 20 with medium force and hold it with a spanner to prevent it from turning. Tighten screw 21 with an allen key. 			<ul style="list-style-type: none"> ■ Mount group of parts 20: put the blank washer on stem 8, put the red washer between the stopper and the nut and lock it by tightening the nut. 			

Diaphragm valve type 14

Assembly and maintenance procedure

DN 15 up to DN 50

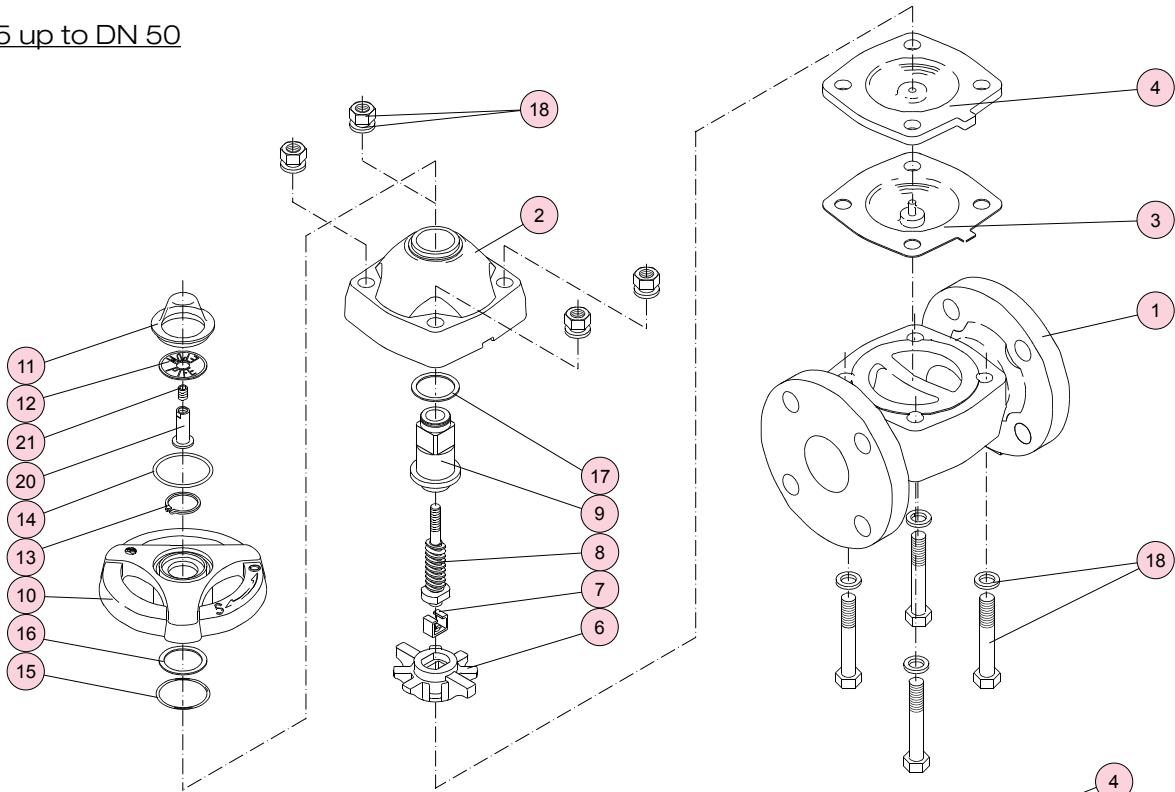

DN 65 up to DN 100

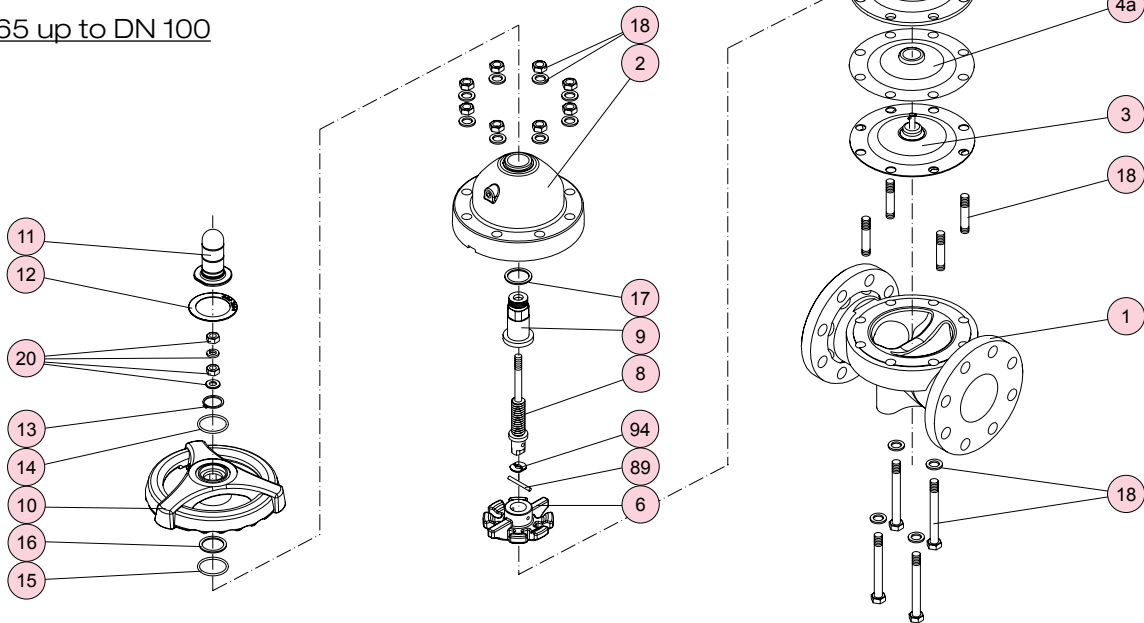

all DN

Notes for correct installation

- The valve must be installed stress-free in the pipe (plane parallelism, axial, overall length).
- Flange version:
Tighten the connecting screws evenly and crosswise (observe tightening torques).
In general, use washers for the nuts and bolts in plastic flanges.
- Spigot end and socket end version:
Connect valve and pipe according to the relevant specifications for gluing and welding.