

SRD998 Intelligent Positioner with HART Communication



The intelligent positioner SRD998 is designed to operate pneumatic valve actuators and can be operated from control systems (e.g. the I/A Series System and Evo™), controllers or PC-based configuration and operation tools such as the FDT/DTMs VALcare™. The positioner is available with HART 7 Communication Protocol. The extra large multi-lingual full text graphical-LCD, in conjunction with the rotary selector, allows a comfortable and easy local configuration and operation. For installations in contact with explosive atmospheres certificates are available.

FEATURES

- ▶ Auto-start with self-calibration
- ▶ Self diagnostics, status and diagnostic messages
- ▶ DTM for valve diagnostics and predictive maintenance
- ▶ Easy local operation with the rotary selector
- ▶ Extra large multi-lingual full text graphical LCD. SRD998 AD model with backlight.
- ▶ With HART 7 communication
- ▶ Stroke 8 to 260 mm (0.3 to 10.2 in) with standard lever; larger stroke with special lever
- ▶ Angle range up to 95° (up to 120° on request)
- ▶ Mounting onto any linear or rotary actuator
- ▶ Supply air pressure up to 10 bar (145 psig)
- ▶ Single or double acting
- ▶ Protection class IP 66
- ▶ Explosion protection: Intrinsic Safety according to ATEX/IECEX, INMETRO, NEPSI, PESO, CNS, EAC, KCs, and TIIS

*Equipment should be installed, operated, serviced, and maintained only by qualified personnel.
No responsibility is assumed by Schneider Electric for any consequences arising from the use of this material.*

DESIGN

Figure 1. Design

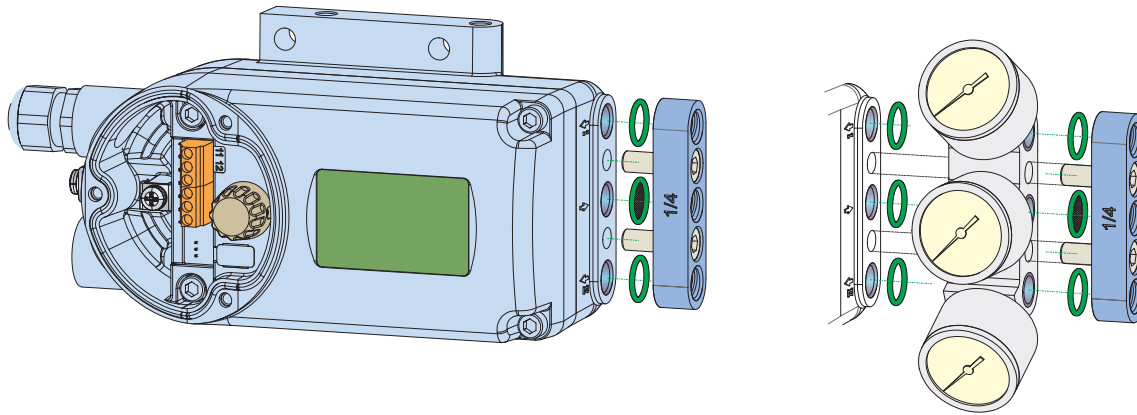

Using the modular concept of the SRD998, the positioner can be optimally adapted to the application. In addition to connection manifolds with various threads, mounting kits for each drive and extensive accessories, these also include integrated pneumatic amplifiers in various performance classes.

Pneumatic Amplifiers

Depending on the actuator, a single or double-acting pneumatic amplifier is used.

- ▶ Codes Bxx - Single Acting
- ▶ Codes Cxx - Double Acting

Single-acting pneumatics have versions B0S, B1S and B2S that differ in air flow. For the double-acting pneumatics, there are the versions C0S, C1S and C3S, which differ in the air performance.

For drives with increased air output, a correspondingly powerful supply air station is required.

TECHNICAL DATA

Supply

Supply air pressure

- ▶ B0S, C0S - 1.4 to 6 bar (20 to 87 psig)
- ▶ B1S, B2S - 1.4 to 10 bar (20 to 145 psig)
- ▶ C1S, C3S - 1.4 to 10 bar (20 to 145 psig)

Output to actuator - 0 to ~100% of supply air pressure (up to 5.5 bar at 6 bar supply air pressure)

Air supply - according to ISO 8573-1

- ▶ Solid particle size and density class 2
- ▶ Oil rate - class 3
- ▶ Pressure dew point 10 K under ambient temperature

We recommend the use of a filter regulator for air supply of the positioner. It reduces the air pressure to the actuator's maximum pressure, keeps it constant, and filters the air. For the pneumatics with standard flow (B0S, B1S, C0S) we recommend the FRS02, FRS03, or FRS923 filter regulator. When using other brands, a filter grade of 30 µm or better is supported.

For the pneumatics with high flow (B2S, C1S, C3S) we recommend the High Flow Filter Regulator FRS04 or FRS05 with a filter grade of 5 µm. When using other brands, a filter grade of 5 µm is supported.

Travel Range

Stroke range	8 to 260 mm (0.3 to 10.2 in) with standard feedback levers; special levers on request
Rotation angle range	Without mechanical stop up to 95° angle (up to 120° on request)

Response Characteristic^{(1) (2)}

Sensitivity	< 0.1% of travel span
Non-linearity (terminal based adjustment)	< 0.6% of travel span
Hysteresis	< 0.3% of travel span
Supply air dependence	< 0.1%/1 bar (15 psi)
Temperature effect	< 0.3%/10 K
Mechanical vibration effect according to IEC 60068-2-6 (2007) for 10 to 500Hz up to 2g	
For Pneumatics B0S	▶ < ±0.25% up to 80Hz and 1g ▶ < ±0.25% up to 70Hz and 2g
For Pneumatics B1S, B2S	▶ < ±0.25% up to 70Hz and 1g ▶ < ±0.25% up to 50Hz and 2g
For Pneumatics C0S	▶ < ±0.25% up to 400Hz and 1g ▶ < ±0.25% up to 70Hz and 2g
For Pneumatics C1S, C3S	▶ < ±0.25% up to 55Hz and 2g

In case of high vibrations, we recommend using remote mounting solution.

Note for Single/Double Acting Operation

For optimal control performance, we do not recommend the use of double acting positioners onto single acting actuators.

1. Data measured according to VDI/VDE 2177 and IEC 61514-2
2. With 90° angle, rotary actuator

USABILITY

SRD998 Pneumatic Type		SRD998 Pneumatic Technique	Recommended Filter Regulator	Booster, if required
Single Acting	B0S	Diaphragm Amplifier	FRS923/FRS02/FRS03	VBS200/VBS300 Series
Double Acting	C0S	Diaphragm Amplifier	FRS923/FRS02/FRS03	VBS200/VBS300 Series
Single Acting	B1S	Diaphragm Amplifier	FRS923/FRS02/FRS03	VBS200/VBS300 Series
Single Acting	B2S	Diaphragm Amplifier	FRS04/FRS05	VBS200/VBS300 Series
Double Acting	C1S	Spool Valve	FRS04/FRS05	Booster not recommended
Double Acting	C3S	Spool Valve	FRS04/FRS05	Booster not recommended

PNEUMATIC PERFORMANCE - AIR FLOW

Pneumatic Performance - Air Flow			
Air flow at Air Input/Output	3 bar		
Pneumatic Code B0S (Single Acting - Standard Flow, Standard Pneumatic)			
to pressurize actuator	7000		NI/h
to vent actuator	5000		NI/h
Pneumatic Code B1S (Single Acting - Standard Flow, High Performance Pneumatic)			
to pressurize actuator	7000		NI/h
to vent actuator	5000		NI/h
Pneumatic Code B2S (Single Acting - High Flow, High Performance Pneumatic) Cv 0.58			
to pressurize actuator	21500		NI/h
to vent actuator	15000		NI/h
Pneumatic Code C0S (Double Acting - Standard Flow, Standard Pneumatic)			
to pressurize actuator	5000		NI/h
to vent actuator	3750		NI/h
Pneumatic Code C1S (Double Acting - Standard Flow, High Performance Pneumatic)			
to pressurize actuator	7000		NI/h
to vent actuator	7000		NI/h
Pneumatic Code C3S (Double Acting - Very High Flow, High Performance Pneumatic) Cv 0.85			
to pressurize actuator	33500		NI/h
to vent actuator	33500		NI/h

Recommended pneumatics, depending on the actuator size:

- ▶ For actuators < 1 dm³ use the C0S, C1S, B0S, or B1S
- ▶ For actuators > 1 dm³ use the B2S, or C3S

PNEUMATIC PERFORMANCE - AIR CONSUMPTION [NL/H]⁽³⁾

Pneumatic Performance - Air Consumption [NI/h]			
Air consumption at steady state	3 bar		
Pneumatic Code			
B0S (Single Acting - Standard Flow)	250		NI/h
B1S (Single Acting - Standard Flow, High Performance Pneumatic)	400		NI/h
B2S (Single Acting - High Flow, High Performance Pneumatic)	400		NI/h
C0S (Double Acting - Standard Flow)	335		NI/h
C1S (Double Acting - Standard Flow, High Performance Pneumatic)	400		NI/h
C3S (Double Acting - Very High Flow, High Performance Pneumatic)	400		NI/h

3. Measured according to ANSI/ISA-75.13.01-2013

BOOSTERS FOR INCREASED AIR FLOW

Volume Booster Series (to order as accessory)

For large actuators or to reduce action time, a volume booster may be necessary.

VBS200/VBS201

Volume boosters with Cv1.4 and pneumatic connection 1/2"

Optional with Exhaust Collector or Silencer

Figure 2. VBS201 Directly Flanged to the Positioner, Optional with Silencer

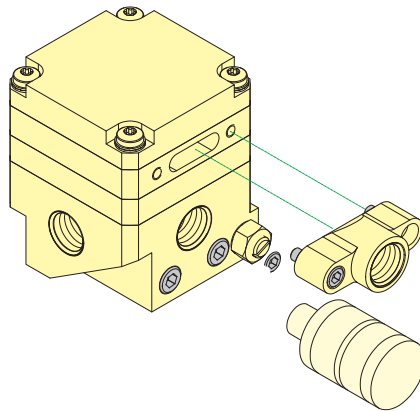
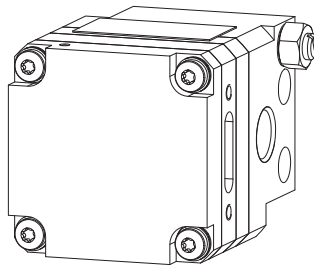
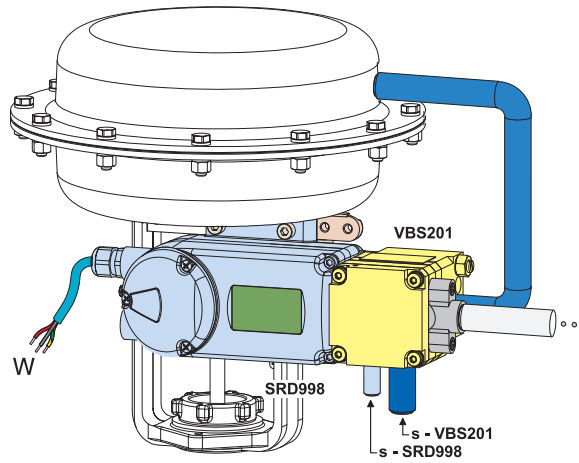

Figure 3. VBS200 for Remote Mounting



For more information, see PSS EVE0602.

Figure 4. Mounting Example 1



VBS300/VBS310

Volume boosters with Cv 7 and pneumatic connection 1" for remote mounting.

Figure 5. VBS300 in Aluminum, VBS310 in Stainless Steel 316

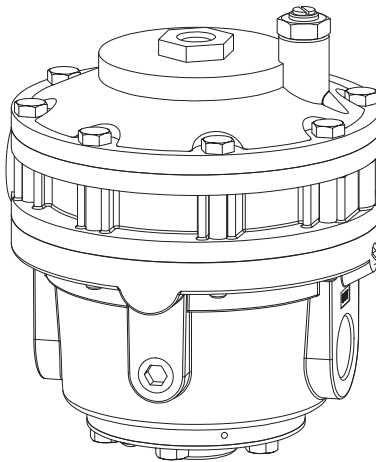

For more information, see PSS EVE0603.

Figure 6. Mounting Example 2

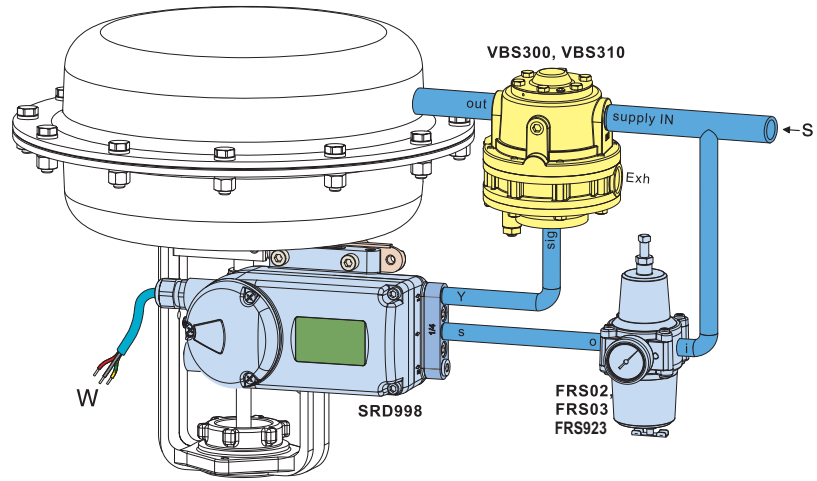

FUNCTIONAL SPECIFICATIONS

FEATURES

Automatic Start-up (Autostart Functionality)

Automatic determination of the mechanical end positions of the valve (initial value and final value), IP motor parameters, direction of action of the spring, and control parameters. The control parameters are optimized dynamically during this routine. This procedure makes an adjustment and optimization to the actuator possible without additional manual settings. Several Autostart modes are available.

OPTIONS

- ▶ Position Feedback 4-20 mA

OPERATION AND CONFIGURATION

The local LCD enables a fast and easy configuration as well as clear diagnostic messages.

- ▶ Local - with local rotary selector.
- ▶ Display - multi lingual graphic LCD. SRD998 AD model with backlight.

The positioner contains the following menu languages:

English, German, French, Chinese, Portuguese, Spanish, Polish, Korean, Swedish, Italian, Russian, Turkish, Japanese, and Czech.

MANUAL LOCAL AND REMOTE SETTINGS

Table 1. Manual Local and Remote Settings

Actuator mode ▶ Linear valve ▶ Rotary actuator	Linear or rotary actuator ▶ Left or right mounted ▶ Opening clockwise or counter-clockwise
Valve characteristic	Linear, equal percentage, inverse-equal percentage or custom (22 points)
Valve action	Opens or closes with increasing set point
Split range	Free upper and lower values
Travel limits	Free upper and lower values
Cutoffs	Free upper and lower values
Stroke range	Configurable
Temperature unit	Configurable (°C or °F)
Autostart	▶ Endpoints ▶ Standard Autostart ▶ Enhanced Autostart ▶ Smooth response ▶ Fast response ▶ PI only
Control parameters	Determined during Autostart
Working range	Freely adjustable (for indication on LCD)
Manual adjustment of	P-gain, I-time, D-time, T63-time, and dead band
Manual operation	Manual input of set point to drive the valve in steps of 12.5% or 1%
Pneumatic test	Function to test the pneumatic output
LCD orientation	Standard, and upside down

SOFTWARE SUPPORTED CONFIGURATIONS

- ▶ By means of Hand Held Terminal (HART)
- ▶ PC by means of VALcare DTM Software
- ▶ I/A Series System, Evo™ and other DCS

ISSUE HANDLING

In case of Single Acting, Safety position at

- ▶ Air supply loss - pressure $Y_1 = \text{zero}$
- ▶ Electric power loss - pressure $Y_1 = \text{zero}$
- ▶ Electronics issue - pressure $Y_1 = \text{zero}$

In case of Double Acting or spool valve amplifier, safety position at

- ▶ Air supply loss - pressure $Y_1 = \text{zero}; Y_2 = \text{zero}$
- ▶ Electric power loss - pressure $Y_1 = \text{zero}; Y_2 = \text{full air supply pressure}$
- ▶ Electronics issue - pressure $Y_1 = \text{zero}; Y_2 = \text{full air supply pressure}$

DIAGNOSTIC

To monitor the high performance of the positioner, see Table 2.

Table 2. Diagnostic Utilities

Type	Basic Diagnostics	Advanced Diagnostics
Configuration data surveillance	Yes	Yes
Input current adjustment surveillance	Yes	Yes
A/D converter surveillance	Yes	Yes
Position value surveillance	Yes	Yes
Connection to I/P converter surveillance	Yes	Yes
Potentiometer surveillance	Yes	Yes
Angle adjustment surveillance	Yes	Yes
Surveillance of reaching the set point in a specific time	Yes	Yes
Temperature limit min or max surveillance	Yes	Yes
Autostart surveillance	Yes	Yes
Custom Characterization		Yes
Auto diagnostic		Yes
Alarm Management		Yes
Alarm Output for Switching (with Option board)		Yes
Status List according to NE107		Yes
Position History		Yes
Response History		Yes
Step Response Analyze		Yes

PHYSICAL SPECIFICATIONS (COMMON DATA FOR ALL VERSIONS)

Mounting

Attachment to Stroke Actuators

- ▶ For casting yoke according to IEC 534-6 (NAMUR) with attachment kit EBZG –H or –H1
- ▶ For pillar yoke according to IEC 534-6 (NAMUR) with attachment kit EBZG –K or –K1

Stroke range with feedback lever:

- ▶ Standard (EBZG-A) - 8 to 80 mm/0.31 to 3.15 in
- ▶ Extended (EBZG-B) - 60 to 120 mm/2.36 to 4.72 in
- ▶ Extended (EBZG-A1) - 110 to 260 mm/4.33 to 10.24 in

Larger stroke ranges can be realized with special levers.

Attachment to Rotary Actuators according to VDI/VDE 3845

With Attachment Kit - EBZG -R

- ▶ Further Attachment kits, see “MODEL CODE ACCESSORIES”

Materials

Housing and covers	Aluminum Alloy No. 230 (GD-AISi12) Polyester Powder coated
Sealings between covers	Silicone elastomer and silicone core with Ag/Cu particles
LCD Window	Polycarbonate, U.V. stabilized
External Screws	Stainless Steel V2A 1.4301
Motherboard	Coated with protective resin
All moving parts of feedback system (e.g. shaft)	1.4306/1.4571/1.4104
Attachment kits	V4A 1.4401 or (depending upon version). Aluminum Alloy No. 230 (GD-AISi12) finished with DD varnish
Mounting bracket	Aluminum Alloy No. 230 (GD-AISi12)
Pneumatic diaphragms	VMQ, PVMQ (Silicone Elastomer, suitable for use in the paint industry) (depending upon version)

Weight

With pneumatic

- ▶ B0S - approximately 2.1 kg (4.7 lbs)
- ▶ B1S/B2S - approximately 2.2 kg (4.9 lbs)
- ▶ C0S - approximately 2.3 kg (5.1 lbs)
- ▶ C1S/C3S - approximately 2.2 kg (4.9 lbs)

Pneumatic Connection

NAMUR mounting - G 1/4 or 1/4-18 NPT via manifold

Electrical Connection

Line entry	1 cable gland M20 x1.5, 1/2-14 NPT (with Adapter AD-)
Cable diameter	6 to 12 mm (0.24 to 0.47 in)
Screw terminals	2 terminals for input loop. Model AD with Universal In-Out Option (position feedback): 4 terminals for additional inputs/outputs
Wire cross section	0.3 to 2.5 mm ² (AWG 22-14) max torque 0.6 Nm

Ambient Conditions

Operating conditions	According to IEC 654-1, the device can be operated at a class Dx location
Ambient temperature	Operation -40 to 80°C (-40 to 176°F) Transport and storage -40 to 80°C (-40 to 176°F) If the device is exposed to sunlight and the temperature may rise above 80°C/176°F, we recommend a sun shade.
Storage conditions According to IEC 60721-3-1	1K5; 1B1; 1C2; 1S3; 1M2
Indicators LCD (visible) (a)	-25 to 70°C (-13 to 158°F)
Relative humidity	Up to 100%
Protection class ▶ According to IEC 60529	IP 66

a. At temperatures less than -20°C the LCD reacts only slowly; at temperatures greater than +70°C the background becomes dark (no damage when back into -20 to +70°C range)

Electromagnetic Compatibility EMC

Operating conditions	Industrial environment
Immunity according to ▶ EN 61326 ▶ IEC 61326 ▶ EN 61000-6-2	Fulfilled Fulfilled Fulfilled
Emission according to EN 61326 Class A and Class B	Fulfilled
EN 61000-6-2	Fulfilled
EN 55011 Group 1 Class A and Class B	Fulfilled
NAMUR recommendation EMV NE21	Fulfilled

Safety Requirements

CE Label

Electromagnetic Compatibility	2014/30/EU
Low-voltage regulation	Not applicable See Declaration of Conformity
Explosion Protection	2014/34/EU
RoHS2	2011/65/EU

Safety

According to EN 61010-1 (or IEC 61010-1)	Safety class III Overvoltage Category I
External circuit breakers	Limitation of power supplies for fire protection is required according to EN 61010-1, appendix F (or IEC 61010-1).

ELECTRICAL CERTIFICATIONS⁽⁴⁾ ⁽⁵⁾

These positioners have been designed to meet the electrical safety descriptions listed in the following table. For detailed information or status of testing laboratory approvals/certifications, contact Global Customer Support.

Certification	Model Code Option
Intrinsically Safe according to ATEX/IECEX II 2G Ex ia IIC T6...T4 Gb; II 1D Ex ia IIIC (a) or IIIB (b) T100°C Da	A1
Intrinsically Safe according to ATEX/IECEX II 2G Ex ib IIC T6...T4 Gb; II 2D Ex ib IIIC (a) or IIIB (b) T100°C Db	A2
Intrinsically Safe according to ATEX/IECEX II 3G Ex ic IIC T6...T4 Gc; II 3D Ex ic IIIC (a) or IIIB (b) T100°C Dc	A3
INMETRO: Ex ia IIC T4/T6 Gb, Ex ia IIIC T100°C Da, IP66 (a)	B1
INMETRO: Ex ib IIC T4/T6 Gb, Ex ib IIIC T100°C Db, IP66 (a)	B2
INMETRO: Ex ic IIC T4/T6 Gc, Ex ic IIIC T100°C Dc, IP66 (a)	B3
NEPSI: Ex ia IIC T4/T6 Ga, Ex iaD 20 T100 Da, IP66 (a)	N1
NEPSI: Ex ib IIC T4/T6 Gb, Ex ibD 21 T100 Db, IP66 (a)	N2
NEPSI: Ex ic IIC T4/T6 Gc, Ex icD 22 T100 Dc, IP66 (a)	N3
EAC: 1 Ex ia IIC T4/T6 Gb X, Ex ia IIIC T100°C Da (a)	G1
EAC: 1 Ex ib IIC T4/T6 Gb X, Ex ib IIIC T100°C Db (a)	G2
EAC: 2 Ex ic IIC T4/T6 Gc X, Ex ic IIIC T100°C Dc (a)	G3
KCs (Korean Certificate Safety): II 2G Ex ia IIC T4/T6 Gb, II 1D Ex ia IIIC T100°C Da, IP66 (a)	K1
KCs (Korean Certificate Safety): II 2G Ex ib IIC T4/T6 Gb, II 2D Ex ib IIIC T100°C Db, IP66 (a)	K2
KCs (Korean Certificate Safety): II 3G Ex ic IIC T4/T6 Gc, II 3D Ex ic IIIC T100°C Dc, IP66 (a)	K3
CNS certification: The SRD998 has the CNS certificate for usage in Taiwan. (a)	
PESO certification: The SRD998 has the PESO certificate for usage in India. (a)	

a. For Model BD.

b. For Model AD.

For use in hazardous areas in certified safe circuits with the following maximum values for Model SRD998 BD (Certification number: IBExU15ATEX1109X):

Pi	Ui	Ii	T4	T6
900 mW	30 V	130 mA	-40°C to 80°C	
660 mW	28.1 V	130 mA	-40°C to 80°C	-40°C to 44°C
630 mW	25.7 V	130 mA	-40°C to 80°C	-40°C to 46°C
590 mW	25.3 V	130 mA	-40°C to 80°C	-40°C to 48°C
510 mW	26 V	130 mA	-40°C to 80°C	-40°C to 52°C

Li = < 10 µH

Ci = < 2.5 nF

IP degree according to IEC 60529 - IP 66

4. With appropriate order only.

5. National requirements are observed.

For use in hazardous areas in certified safe circuits with the following maximum values for Model SRD998 AD (Certification number: IExU20ATEX1044X):

Supply and sensor circuit in protection type intrinsic safety Ex ia IIC (Terminal + 11/-12)

Ui 30 V / li 130 mA

Pi (T4) 0.9 W / Pi (T6) 0.515 W

Ci 25 nF / Li 1 μ H

UNI-I/O module circuit in protection type intrinsic safety Ex ia IIC (channel 1: + 13 /-14 and channel 2 (position feedback): + 15 /-16)

Ui 30 V / li 130 mA

Pi (T4) 0.9 W (channel 1) or 0.66 W (channel 2)

Pi (T6) 0.550 W (channel 1) or 0.386 W (channel 2)

Ci 28 nF / Li 2 μ H

Ambient temperature range:

-40°C up to +80°C (T4)

-40°C up to +40°C (T6)

Torque Definitions for SRD998

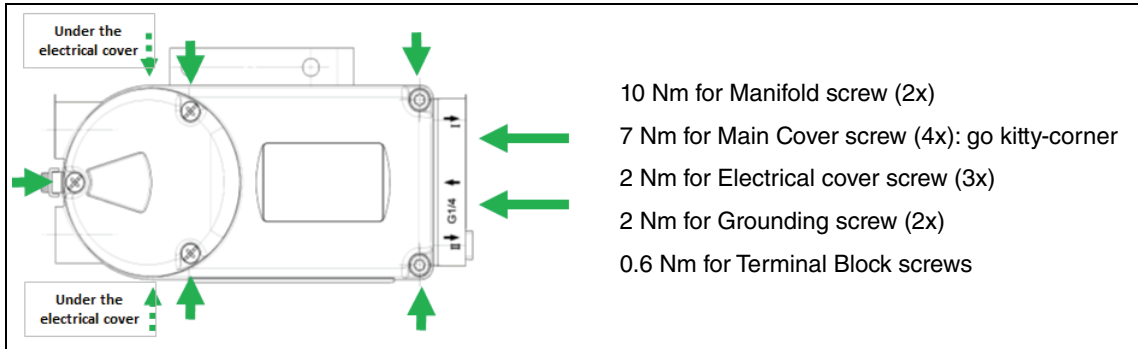

SRD998 WITH HART COMMUNICATION

Signal Input	Two wire system
Reverse polarity protection	Standard feature
Signal range	4 to 20 mA
Operating range	3.6 to 21.5 mA
Input voltage (a)	DC 12 to 36 V (unloaded) (a) ▶ min 12 V at 4 mA ▶ min 8.4 V at 20 mA
Load	420 Ohms, 8.4 V at 20 mA
Communication signal	HART 7, 1200 Baud, FSK (Frequency Shift Key) modulated on 4 to 20 mA 0.5 Vpp at 1 kOhm load
Input impedance Zi	Z = 320 Ohms for ac voltage 0.5 to 10 kHz with < 3 dB non-linearity (b) (c) (d)
Start-up time	Approximately 3 seconds
Interruption time without power down	Typ. 8 ms (e)

- a. Higher voltage limits may be available upon request.
- b. Cable capacity and inductance see HART standard specifications (e.g. C < 100 μF).
- c. Impedance of other devices at the input (parallel or serial) have to be within HART specifications.
- d. Applications without communication cannot exceed input capacitance parallel to the input not higher than 5μF.
- e. Worst case conditions 4-20 mA, I/P-Output with maximum current.

Configuration

The SRD998 positioner can be configured via HART by any host system using PC with a HART Modem, Hand Held Terminal or a DCS.

Local

By means of rotary selector and LCD display.

DTM (Device Type Manager)

The DTM can be downloaded from the Schneider Electric homepage:

<https://www.schneider-electric.com/en/download/range/63514-Valve%20Positioners/?docType=4889330-DTM+files>

The DTM is fully certified for its interoperability and with the state-of-the-art presentation and diagnostics features.

DD (Device Description) and EDD (Enhanced Device Description)

In case the host system is not supporting the FDT-DTM technology, you can download the DD and/or EDD from the Schneider Electric home page.

Figure 7. Sample Intelligent Positioner SRD998

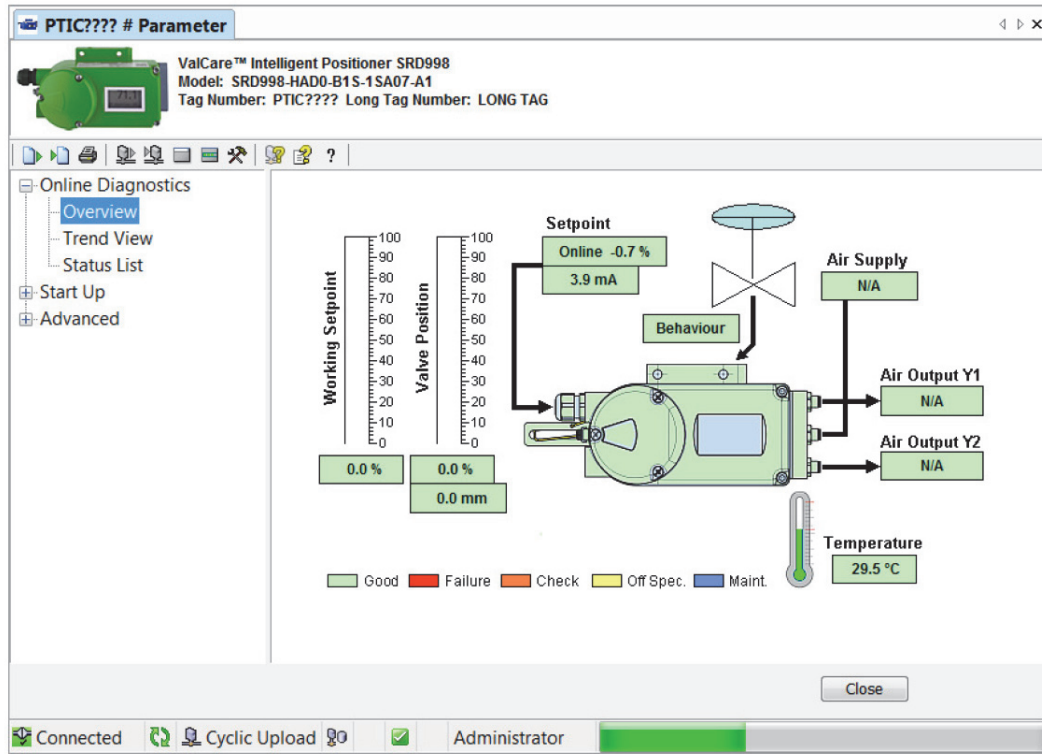

FUNCTIONAL DESIGNATIONS

Figure 8. Functional Designations

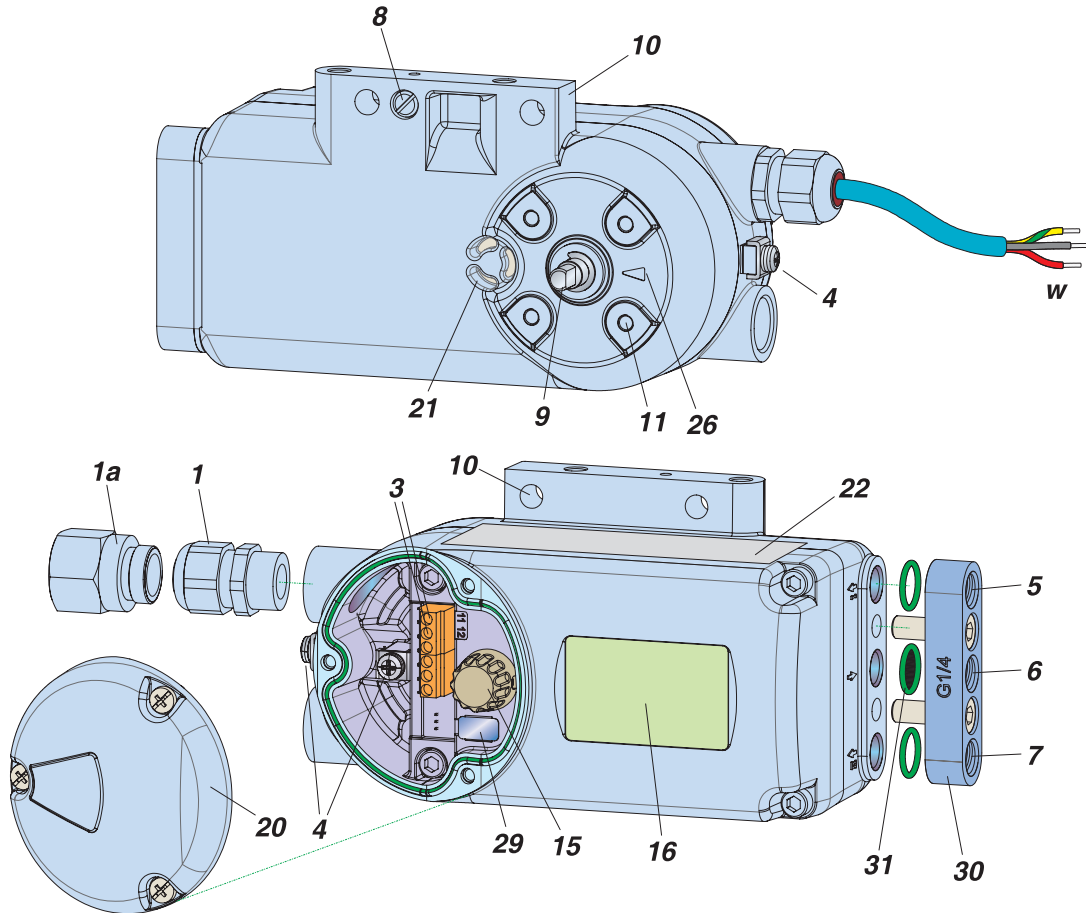

- | | |
|--|--|
| <p>1 Cable gland</p> <p>1a Adapter, e.g. 1/2"-14 NPT</p> <p>3 Terminal Block (a) (see Figure 9 for screw terminals: +11 and -12 for input loop and +13, -14, +15, and -16 for Universal In-Out Option Code 1)</p> <p>4 Ground connection (inner and outer)</p> <p>5 Output I (y1)</p> <p>6 Air supply (s)</p> <p>7 Output II (y2)</p> <p>8 Direct attachment hole for output I (y1)</p> <p>9 Feedback shaft</p> <p>10 Connection manifold for attachment to stroke actuators</p> | <p>11 Connection base for attachment to rotary actuators</p> <p>15 Turn Rotary Selector for Menu selection and press to confirm</p> <p>16 LCD with true text in different languages</p> <p>20 Cover for electrical connection compartment</p> <p>21 Air vent, dust and water protected</p> <p>22 Data label</p> <p>26 Arrow is perpendicular to feedback shaft at angle 0 degree</p> <p>29 Plug for service connector under the lid (factory only)</p> <p>30 Connecting manifold, G 1/4 or 1/4 NPT Not required when mounting a gauge manifold, or a direct mounted volume booster</p> <p>31 O-ring with filter, for air supply connection</p> |
|--|--|

a. Test sockets (diameter sign) 2 mm, integrated in terminal block.

Figure 9. Detail of Terminal Block for Model SRD998 AD

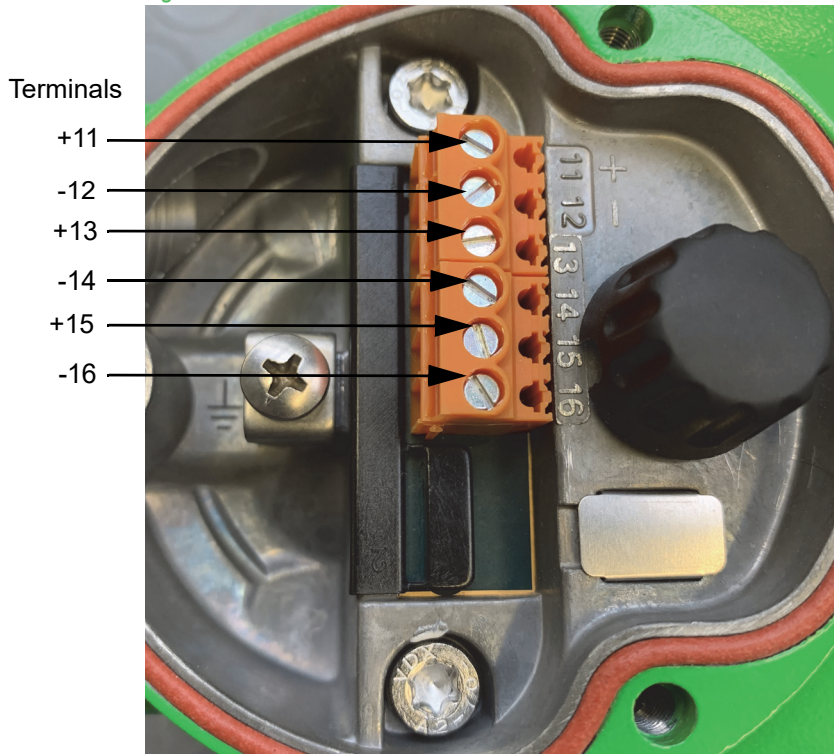

ADDITIONAL EQUIPMENT

Additional Inputs/Outputs: –Code 1

Position Feedback 4-20 mA and Alarm with Electrical Classification ATEX/IECEX

Stroke/angle derived from positioner feedback:
One output analog, galvanically separated, two-wire system according to DIN 19234, for external power supply

Supply Voltage:	DC 8 to 36 V
Signal Range:	3.8 to 20.5 mA
0% and 100% configurable	
Device fault:	< 200 µA
Terminal for Position Feedback (channel 2):	+15 -16
Feedback signal can be reversed (20→ 4 mA)	

Electrical Classification ATEX/IECEX for Additional Inputs/Outputs: –Code 1 (Certification number: IBExU20ATEX1044X)

For electrical ATEX/IECEX classification, see “ELECTRICAL CERTIFICATIONS” on page 13.

Certified under EU-Type Certificate of Conformity IBExU20ATEX1044X and IECEX Certificate of Conformity IECEX IBE 20.0005X.

Certified as intrinsically safe for use in hazardous areas with the maximum values as described in the Certificate of Conformity.

The circuits Channel 1 and Channel 2 are electrically separated from each other, from all other external circuits, and from Ground.

Remote Potentiometer: –Code V, W, Y

The remote potentiometer is used in applications where high temperatures or vibration are present and can result in negative influences to the control. It can also be used in places not easy to reach, to help ensure easier handling of the unit, or for cylinders with large strokes. The positioner SRD998, is mounted far away from the valve or cylinder in a safe environment.

The Potentiometer unit is mounted on the valve or cylinder. The Potentiometer unit can be made by RMU998 or by an external potentiometer.

The external potentiometer unit must support a 3-wire system with approximately 5 kOhm resistance.

If the following requirements are fulfilled, the set up is insensitive to electrical disturbances caused by high electromagnetic fields, EMC, and HF radiation.

<p>Cable length maximum: Model BD 3m (9 ft), AD 10m (32 ft)</p> <p>Cable Specifications:</p> <ul style="list-style-type: none"> ▶ 3-wire twisted pair, shielded ▶ Shield needs to be connected on both ends to the internal ground ▶ Shield endings need to be kept very short when connected to Ground ▶ An HF cable gland is not required

For more information about remote mounting, see PSS EVE0118.

NOTE

The functionality and certifications are only ensured with our RMU998.

Electrical Classification ATEX/IECEX

For electrical ATEX/IECEX classification, see “ELECTRICAL CERTIFICATIONS” on page 13.

RMU998 is approved for use with SRD998 (a)(b) under the following certifications:

- a) EU-Type Certificate of Conformity IBEExU15ATEX1109X and IECEX Certificate of Conformity IECEX IBE 15.0028X;
- b) EU-Type Certificate of Conformity IBEExU20ATEX1044X and IECEX Certificate of Conformity IECEX IBE 20.0005X

For use in hazardous areas, the remote potentiometer interface is certified as Intrinsically Safe with the following maximum values:

- Uo = 6 V
- Io = 130 mA
- Po = 0.9 W

The maximum length of the cable between the remote potentiometer and positioner is 3m (for Model BD) and 10m (for Model AD).

Figure 10. Remote Mounting Unit (RMU998)

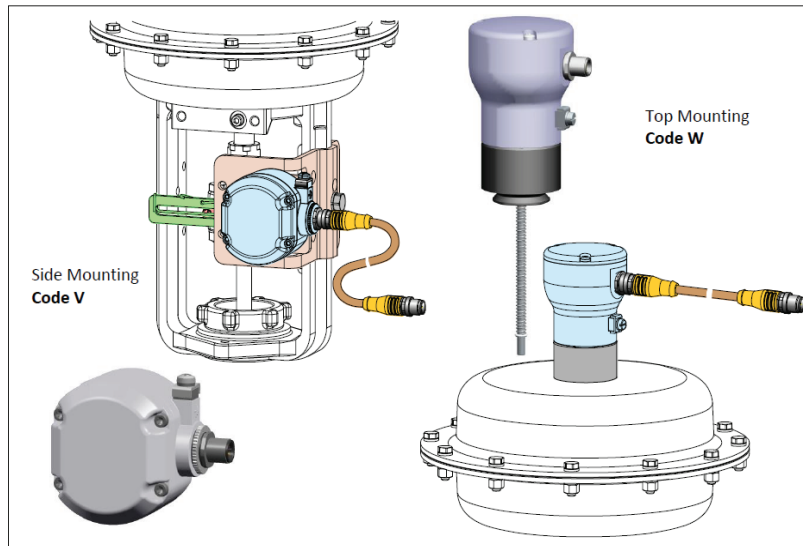

MODEL CODE SRD998

Intelligent Positioner SRD998	Model
<u>Communication</u> HART	H
<u>Diagnostics Performance</u> Basic Diagnostics Advanced Diagnostics	BD AD
<u>Electrical In-Out Option</u> No In-Out Option Universal In-Out Option	0 1
<u>Version</u> Single Acting Double Acting	B C
<u>Pneumatic Performance</u> Standard Pneumatic (6 bar max air supply) Standard Flow - High Performance Pneumatic (10 bar max air supply) High Flow - High Performance Pneumatic (Cv 0.58 – 10 bar max air supply) Very High Flow - High Performance Pneumatic (Cv 0.85 – 10 bar max air supply)	0 1 2 3
<u>Fail in case of loss of power</u> Fail safe	S
<u>Housing</u> Aluminum	1
<u>Mounting</u> Standard Direct mounting Remote Mounting of positioner with side mounting potentiometer unit Remote Mounting of positioner with top mounting potentiometer unit Remote Mounting of positioner w/o potentiometer unit (order potentiometer separately)	S T V W Y
<u>Pneumatic Connection</u> 1/4 NPT 1/4 G	A B
<u>Gauges</u> Without gauge With 2 standard gauges for single acting (a) With 2 Nickel plated gauges connection for single acting (a) With 3 standard gauges for double acting (b) With 3 Nickel plated gauges connection for double acting (b)	0 1 2 3 4
<u>Electrical Connection</u> M20x1.5 1/2 NPT (made with an adaptor)	7 8

HAD1-B0S-1SA0

MODEL CODE SRD998 (CONTINUED)

Intelligent Positioner SRD998	Model
Electrical Certification	
without certification	ZZ
ATEX/IECEX: II 2G Ex ia IIC T6...T4 Gb; II 1D Ex ia IIIC (c) or IIIB (d) T100°C Da	A1
ATEX/IECEX: II 2G Ex ib IIC T6...T4 Gb; II 2D Ex ib IIIC (c) or IIIB (d) T100°C Db	A2
ATEX/IECEX: II 3G Ex ic IIC T6...T4 Gc; II 3D Ex ic IIIC (c) or IIIB (d) T100°C Dc	A3
INMETRO: Ex ia IIC T4/T6 Gb, Ex ia IIIC T100°C Da, IP66 (c)	B1
INMETRO: Ex ib IIC T4/T6 Gb, Ex ib IIIC T100°C Db, IP66 (c)	B2
INMETRO: Ex ic IIC T4/T6 Gc, Ex ic IIIC T100°C Dc, IP66 (c)	B3
NEPSI: Ex ia IIC T4/T6 Ga, Ex iaD 20 T100 Da, IP66 (c)	N1
NEPSI: Ex ib IIC T4/T6 Gb, Ex ibD 21 T100 Db, IP66 (c)	N2
NEPSI: Ex ic IIC T4/T6 Gc, Ex icD 22 T100 Dc, IP66 (c)	N3
EAC: 1 Ex ia IIC T4/T6 Gb X, Ex ia IIIC T100°C Da (c)	G1
EAC: 1 Ex ib IIC T4/T6 Gb X, Ex ib IIIC T100°C Db (c)	G2
EAC: 2 Ex ic IIC T4/T6 Gc X, Ex ic IIIC T100°C Dc (c)	G3
CNS certification IS (c) (d)	
PESO certification IS (c) (e)	
KCs (Korean Certificate Safety): II 2G Ex ia IIC T4/T6 Gb, II 1D Ex ia IIIC T100°C Da (c)	K1
KCs (Korean Certificate Safety): II 2G Ex ib IIC T4/T6 Gb, II 2D Ex ib IIIC T100°C Db (c)	K2
KCs (Korean Certificate Safety): II 3G Ex ic IIC T4/T6 Gc, II 3D Ex ic IIIC T100°C Dc (c)	K3
Options	
Stainless Steel Label, fixed with wire	-L

- a. Only to be ordered with single acting model code Version B.
- b. Only to be ordered with double acting model code Version C.
- c. For Model BD.
- d. The SRD998 has a CNS certificate for usage in Taiwan. Please order with ATEX/IECEX model code.
- e. The SRD998 has a PESO certificate for usage in India. Please order with ATEX/IECEX model code.

ACCESSORIES FOR ALL BASIC DEVICES

Figure 11. Accessories for all Basic Devices

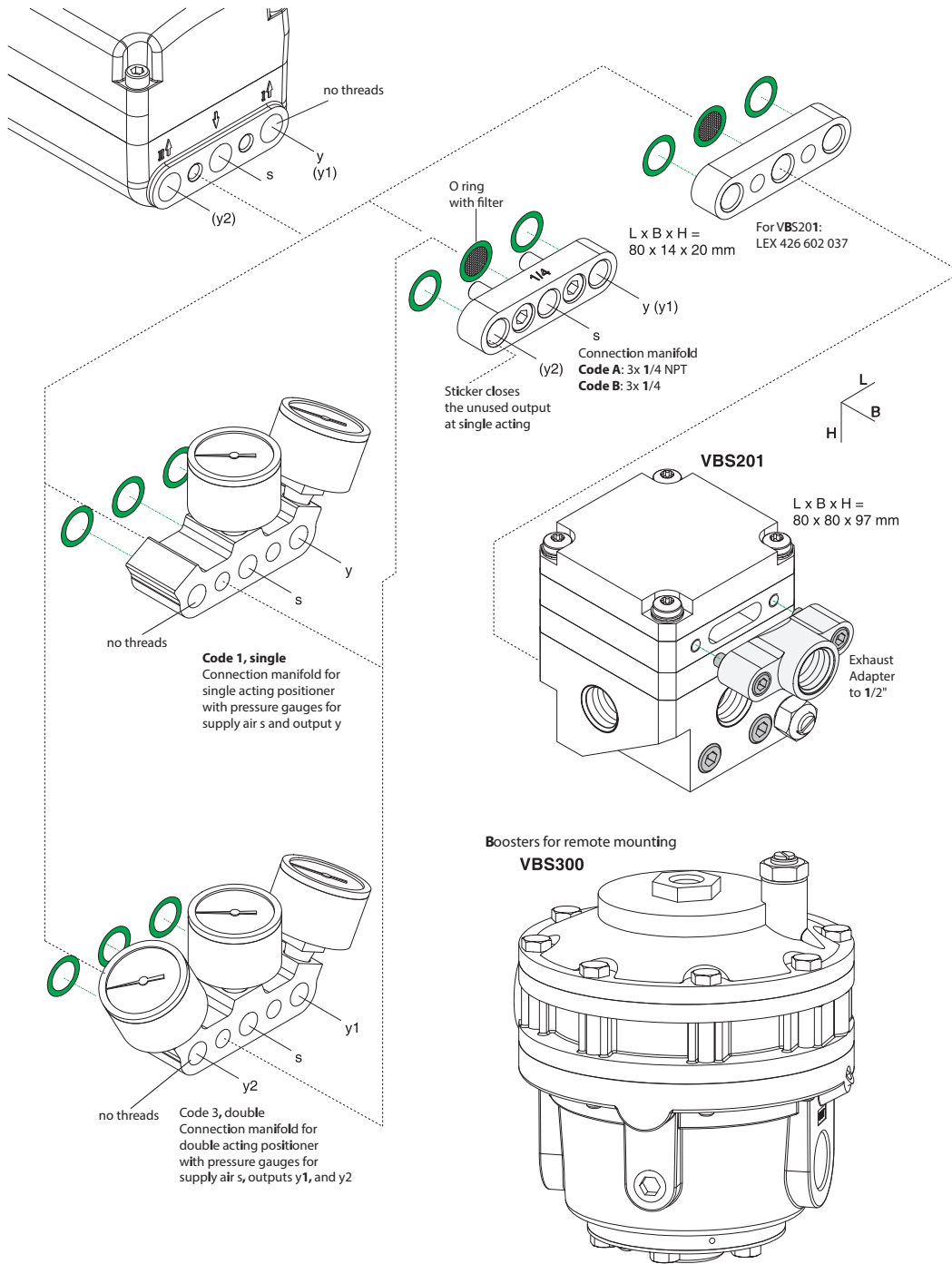

MODEL CODE ACCESSORIES

Accessories for SRD998	Model
<u>Filter Regulators</u>	
Filter Regulator for -30°C to 70°C	FRS02
Stainless Steel (316) Filter Regulator	FRS03
High Flow Filter Regulator 1/2 inch/Aluminum	FRS04
High Flow Filter Regulator 1/2 inch/Stainless Steel	FRS05
Mounting Bracket for FRS02 or FRS03	EBZG-FR1
Orientable Mounting Bracket for FRS02 or FRS03	EBZG-FR2
Nipple for direct mounting Filter regulator 1/4 NPT both sides	VG-91
Mounting Bracket for FRS04	EBZG-FR4
Mounting Bracket for FRS05	EBZG-FR5
Nipple 1/2 NPT (FRS04/05 side) to 1/4 NPT (SRD998 side) for direct piping	VG-93
<u>Communication/Modem/DTM</u>	
HART USB Modem (made by Ifak) with ATEX IS Certification	MOD900
DTM for SRD Series for HART	VALCARE
Service Modem	EDC90
<u>Booster Relay (in case of double acting, quantity 2 pieces)</u>	
Remote version for a positioner	VBS200
Integral volume booster for SRD991, SRD960, SRD998, and SRI990 (directly flanged to positioner)	VBS201
Booster Cv7 - Alum Housing - Remote mounting	VBS300
Booster Cv7 - SS Housing - Remote mounting	VBS310
<u>Limit Switch</u>	
Mechanical Limit Switch weatherproof and plastic housing (TE Sensors XCKN2118P20)	MLS01
<u>Cable Gland</u>	
Cable Gland, M20x1.5 Plastics, Color Gray/Black	BUSG-K6
Cable Gland, M20x1.5 Plastics, Color Blue	BUSG-K7
Cable Gland, M20x1.5 Plastics, Color White	BUSG-K9
Cable Gland, M20x1.5 Stainless Steel	BUSG-S6
<u>Adapter</u>	
Adapter (Brass With Nickel Coating) M20x1.5 to 1/2-14 NPT (Internal Thread)	AD-A5
Adapter (SS) M20x1.5 to 1/2-14 NPT (Internal Thread)	AD-A6
<u>Attachment Kits</u>	
For diaphragm actuators with casting yoke according to NAMUR (incl. standard Couple lever)	-H
For diaphragm actuators with casting yoke according to NAMUR (incl. standard Couple lever)	-H1
- Compact	
Compact stainless steel bracket according to NAMUR	-H6
For diaphragm actuators with pillar yoke according to NAMUR (incl. standard Couple lever)	-K
For diaphragm actuators with pillar yoke according to NAMUR (incl. standard Couple lever)	-K1
- Compact	
For FoxTop/FoxPak	-E1
For mounting to rotary actuators according to VDI/VDE 3845 (without bracket)	-R
Brackets VDI/VDE 3845 (A = 80 mm/3.15 in; B = 20 mm/0.79 in)	-C1
Brackets VDI/VDE 3845 (A = 80 mm/3.15 in; B = 30 mm/1.18 in)	-C2
Brackets VDI/VDE 3845 (A = 130 mm/5.12 in; B = 50 mm/1.97 in)	-C3
Brackets VDI/VDE 3845 (A = 130 mm/5.12 in; B = 30 mm/1.18 in)	-C4
Universal Brackets VDI/VDE 3845 (A = 80 or 130 mm; B=20 or 30 or 50 mm)	-C5

MODEL CODE ACCESSORIES (CONTINUED)

<u>Accessories for SRD998</u>	<u>Model</u>
Couple Lever	<u>EBZG</u>
Standard (stroke max. 80 mm)	A
Extended (stroke max. 260 mm)	-A1
Reduced (stroke < 8 mm)	-A2
Fold feedback lever (stroke 8 to 70 mm)	-A3
Short stroke (stroke 8 to 35 mm)	-A4
Couple Lever Folded (stroke special)	-A5
Extended (stroke max. 120 mm)	-B
Carrier bolt	<u>SRXG</u>
Carrier bolt extra short 23 mm	-A
Adjustable carrier bolt 20 to 37 mm	-B
Carrier bolt 38 mm	-C
Carrier bolt 47 mm	-D
Carrier bolt 57 mm	-E
Carrier bolt 65 mm	-F
Adjustable carrier bolt with fixing system for stem diameter up to 21 mm	-G
Adjustable carrier bolt with fixing system for stem diameter up to 34 mm	-H
Carrier Bolt 80 mm	-I
Adjustable carrier bolt for thread 3/8"	-J
Adjustable carrier bolt for thread 5/16"	-K
Extension for carrier bolt	-L
Adjustable carrier bolt with fixing system centered for stem diameter up to 64 mm	-M
Adjustable carrier bolt with fixing system centered for stem diameter up to 21 mm	-G1
Adjustable carrier bolt with fixing system centered with extension up to 80 mm for stem diameter up to 21 mm	-G2

MOUNTING TO LINEAR ACTUATORS

Figure 12. Attachment to Stroke Actuators according to IEC 534-6 (NAMUR), Left Hand

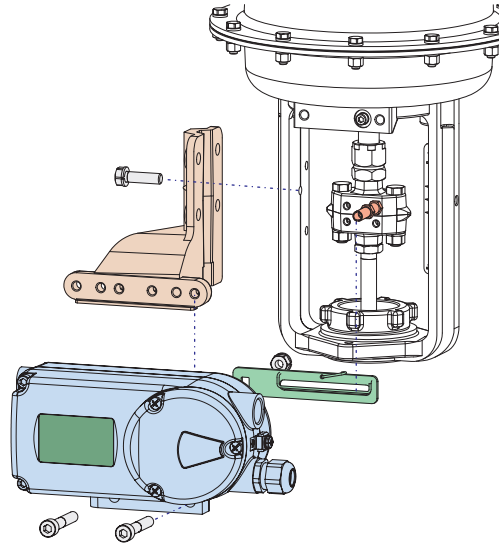

Figure 13. Direct Attachment to Stroke Actuators

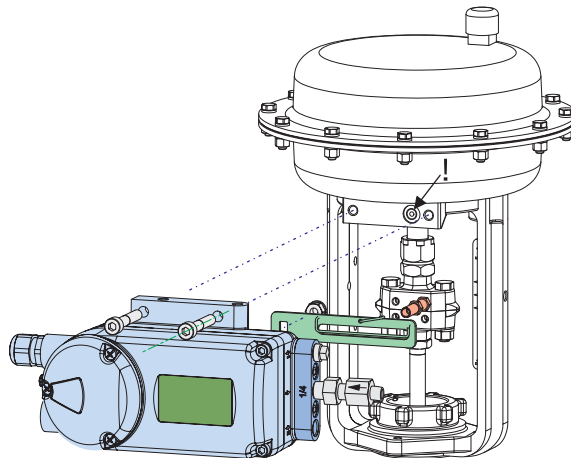

Figure 14. Attachment to Stroke Actuators according to IEC 534-6 (NAMUR), Right Hand, Mounting Bracket EBZG-K

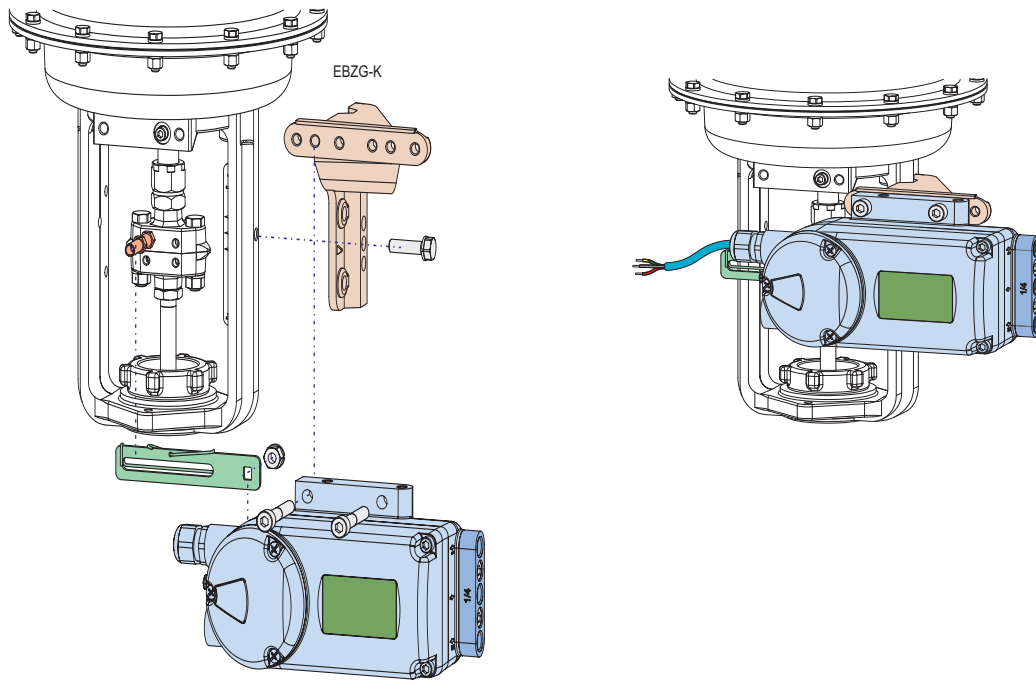
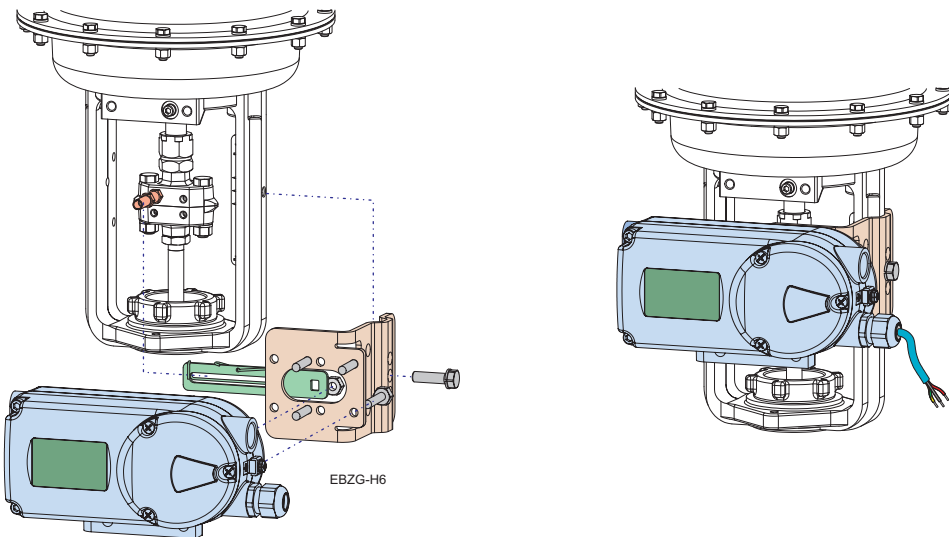
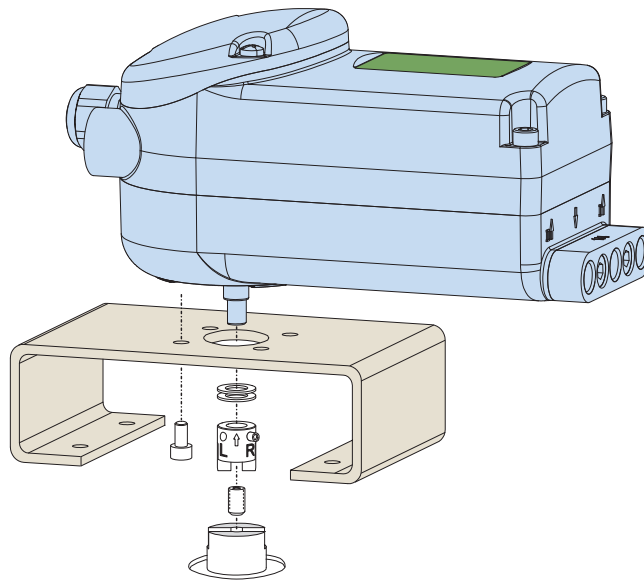

Figure 15. Compact Stainless Steel Attachment Kit with Mounting Bracket EBZG-H6



MOUNTING TO ROTARY ACTUATORS

Figure 16. Delivery of Bracket by Manufacturer of Actuator



DIMENSIONS

Figure 17. Attachment to Rotary Actuator

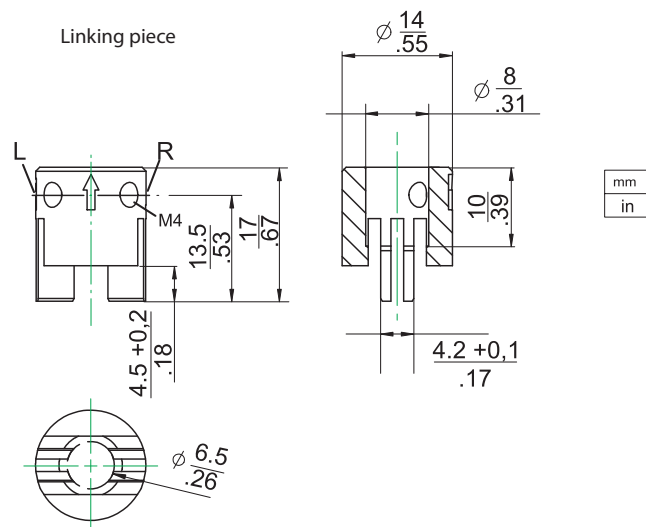
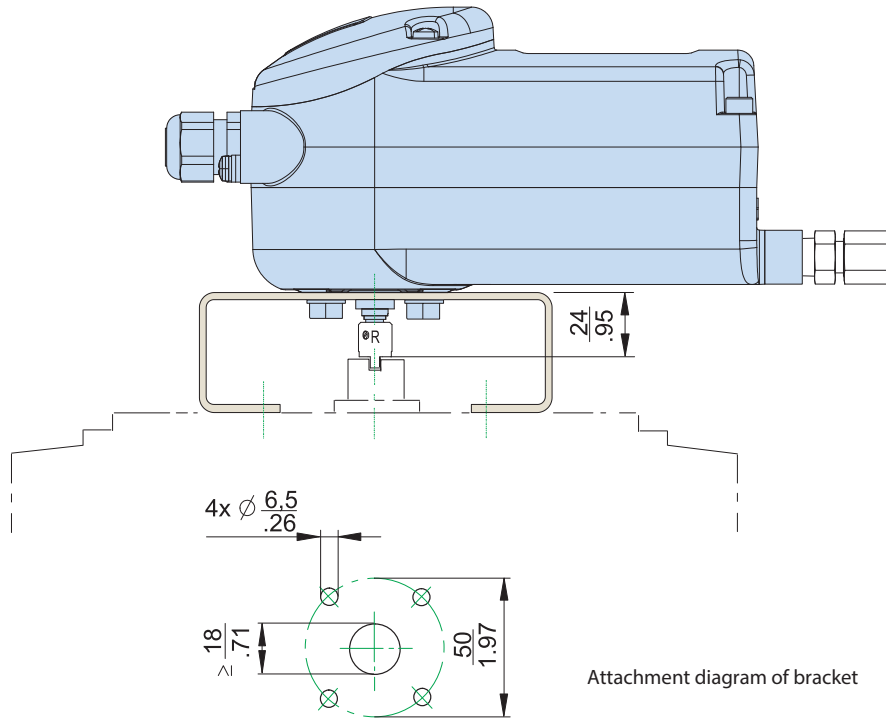

Components of Attachment Kits (Samples)

Figure 18. Components of Attachment Kit

Feedback lever Code EBZG-A for 8 to 80 mm travel

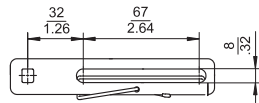

Feedback lever Code EBZG-B for 60 to 120 mm travel

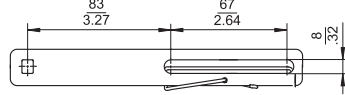

Feedback lever FlowPak/FlowTop in Code EBZG-E1

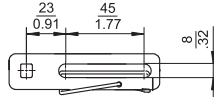

Feedback lever Code EBZG-A1 for 100 to 260 mm travel

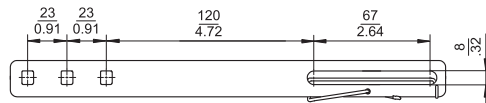

Carrier bolt for connection to valve stem

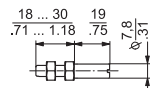

Mounting bracket
e.g. EBZG -H -K

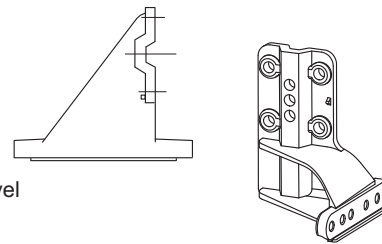
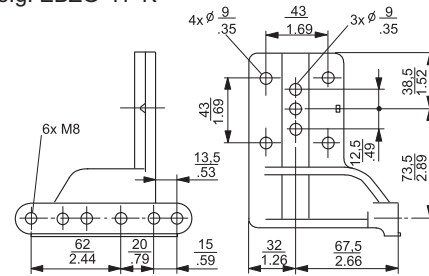

mm
in

Figure 19. Dimensions with Manifold

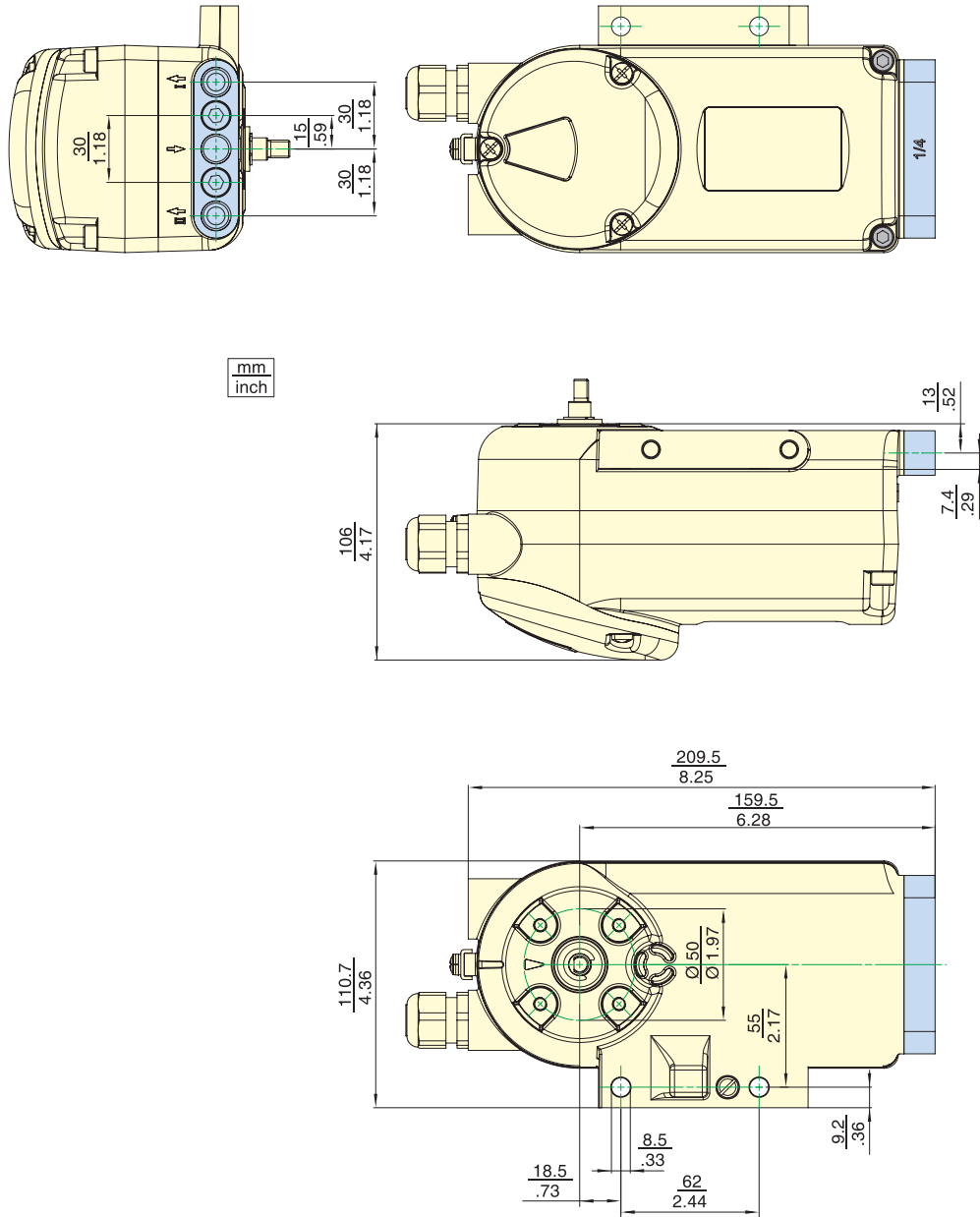
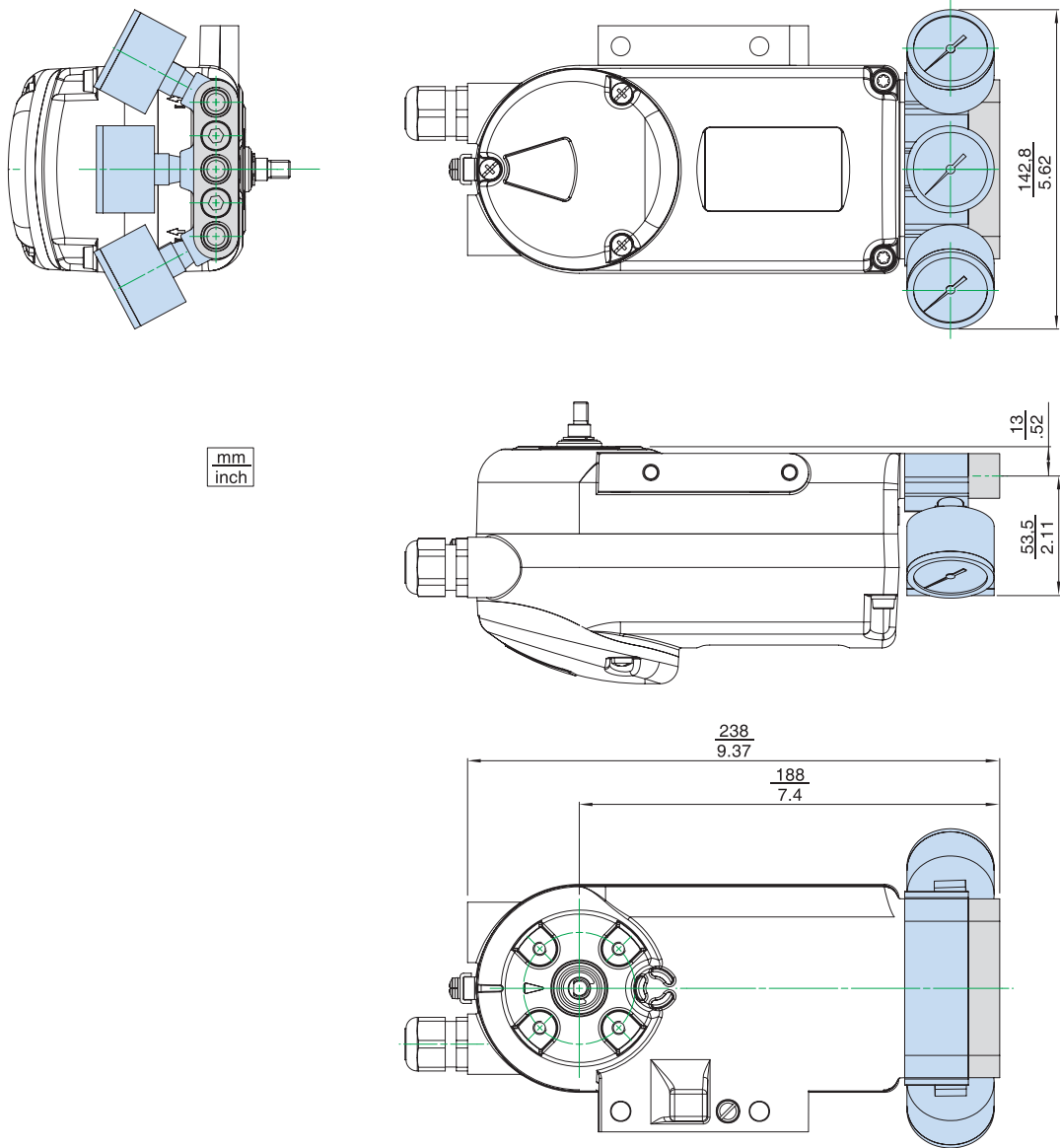

Figure 20. Dimensions with Gauges and Manifold



TYPICAL MOUNTING

Figure 21. SRD998 with Remote Mounting Unit RMU998-V

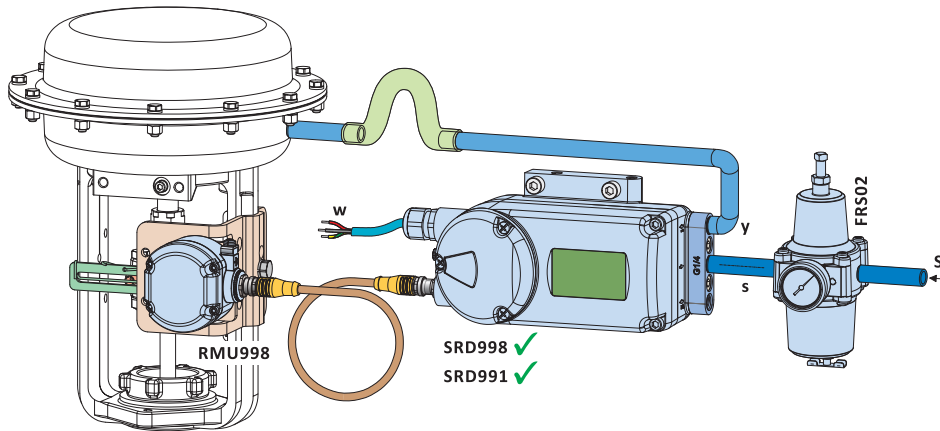
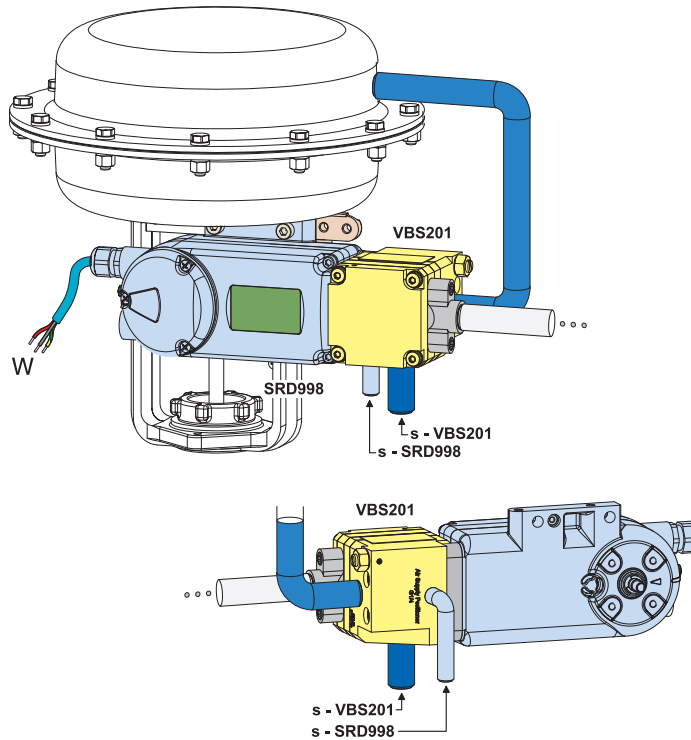

Figure 22. SRD998 with Booster VBS201, Directly Flanged to SRD998 with Connection to an Exhaust Collecting System



NOTES



ADDITIONAL PRODUCTS

These product lines offer a broad range of measurement and instrument products, including solutions for pressure, flow, analytical, temperature, positioning, and controlling. For a list of these offerings, visit our web site at:

www.se.com

Schneider Electric Systems USA, Inc. Global Customer Support
70 Mechanic Street Inside U.S.: 1-866-746-6477
Foxboro, MA 02035 Outside U.S.: 1-508-549-2424
United States of America <https://pasupport.schneider-electric.com>
<http://www.se.com>

Copyright 2010-2020 Schneider Electric Systems USA, Inc. All rights reserved.

The Schneider Electric brand and any trademarks of Schneider Electric SE or its subsidiaries are the property of Schneider Electric SE or its subsidiaries. All other trademarks are the property of their respective owners.

