

**SPECIALTY
CONTROL VALVES
FOR UREA PLANTS**

OUTLINE

PARCOL has started the production of specialty control valves for urea plants in 1965; at present, approximately 200 production units where Parcol valves are installed run with full satisfaction.

1-4800 and 1-2311 series control valves are designed and manufactured so as to grant good service and longer trouble free life with very reduced maintenance. The original and simple design of PARCOL valves as well as the right selection of the part materials result in great success of the same.

Materials are adequate for urea and carbamate fluids and comply with the material specifications for this service of main Licensors such as Snamprogetti, Stamicarbon, Urea Casale and others.

Connections are obtained directly on the single piece that constitutes the valve body in order to keep down the weight, whereas the shape of internals does not leave dead zones. In fact dead zones are a cause for corrosion since carbamate strengthens its corrosive action particularly in these zones due to the failure of oxygen protection (passivation).

GENERAL SPECIFICATIONS

To avoid any problems connected with corrosion caused by environmental conditions stainless steel is widely used for all valve and actuator components: all valve bodies and actuators bolting, body intermediate flanges, clamping nut or screws for fixing the actuators to the bodies, all external packing parts, brackets for installation of pneumatic and electric accessories, pneumatic tubing and fittings are always supplied in stainless steel.

1-4800 series high pressure, split body, angle control valve have one-piece upper body obtained from forged block of specialty stainless steel. Bonnet integral with the body so as to avoid flanged connection and dead zones, streamlined flow design, lenticular coupling between body and seat without the use of any gasket, one-piece plug and stem construction, special packing design and the use of particular trim materials, tested on various plants for many years, are the main features which make PARCOL urea control valves as top as regards quality and performances, at a reasonable price.

Likewise, 1-2311 high pressure butterfly control valves have one-piece body and disc obtained from forged block of specialty stainless steel and special packing design to warrant maximum reliability. Trim materials have been selected by testing on various urea plants for many years to ensure maximum reliability and performances.

4-3111 three way ball valve for urea plant application. Suitable with heating jacket and materials adequate for urea fluids.

Available valve series are:

- 1-4800: Contoured plug, split body angle control valve with three different models:
- 1-4827: General purpose control valve. (*typical services: CO₂ to reactor, reactor vent, carbamate, ammonia*).
- 1-4829: Contoured plug trim with intermediate packing washing. (*typical service: stripper letdown*).
- 1-4824: Multi stage, anti cavitation trim, (up to DN 6"). (*typical service: carbamate pump minimum recirculation flow*).
- 1-2311: High pressure swing through butterfly control valve. (*typical service: carbamate from reactor*).
- 1-2611: High pressure double eccentric butterfly control valve with metal-to-metal seal.
- 4-3111: Three ways ball valve (*typical service: urea melt to the prilling tower*).

Valves can be supplied with various types of actuators according to the required thrusts to guarantee smooth, long lasting and reliable operation, according to specified working conditions and service.

The most used actuators are Parcol pneumatic series 1-X-210 (linear) and 1-X-271 (rotary) with carbon steel yoke and side or top mounted handwheel.

For 1-4800 series, when the required thrust does not allow the use of diaphragm actuators, heavy duty pneumatic piston and spring opposed type, Parcol 1-X-430 series are available. On piston actuators worm gear side mounted handwheel or top mounted hydraulic manual override can be provided. 1-X-430 series piston actuators are of strong and particular design and construction so as to be supplied with instrument air without any lubrication. This guarantees a smooth and really continuous control duty through a pneumatic positioner without the addition of special relays.

In particular circumstances 1-4800 control valves are also supplied with electric actuators for remote and/or local operation for on-off and regulating service.

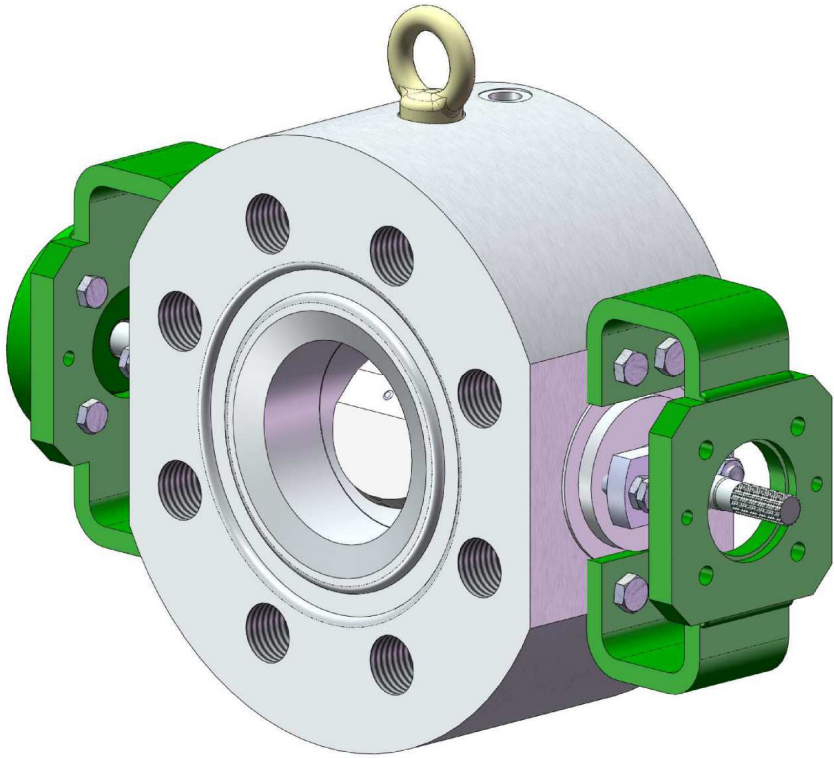

1-2311 SERIES

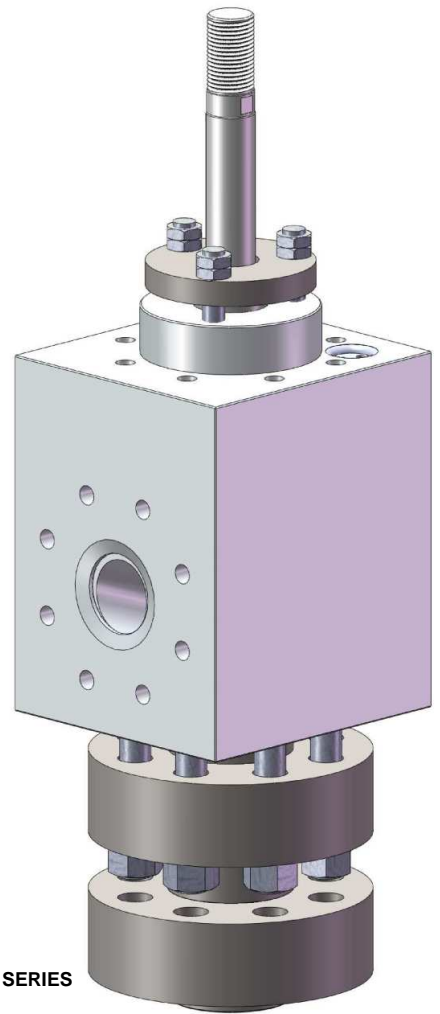

1-4800 SERIES

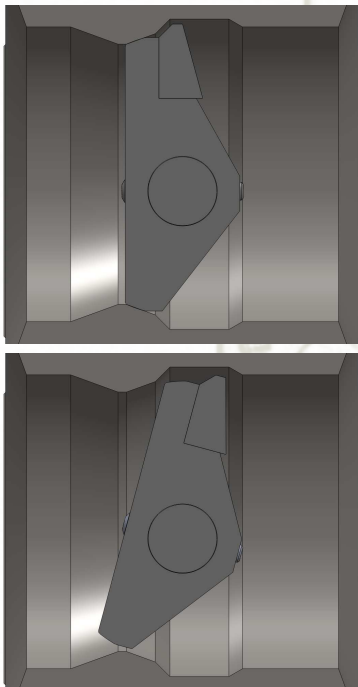

1-2611 Double eccentric vane detail



4-3111 SERIES

AMMONIA STRIPPING UREA PROCESS TECHNOLOGY

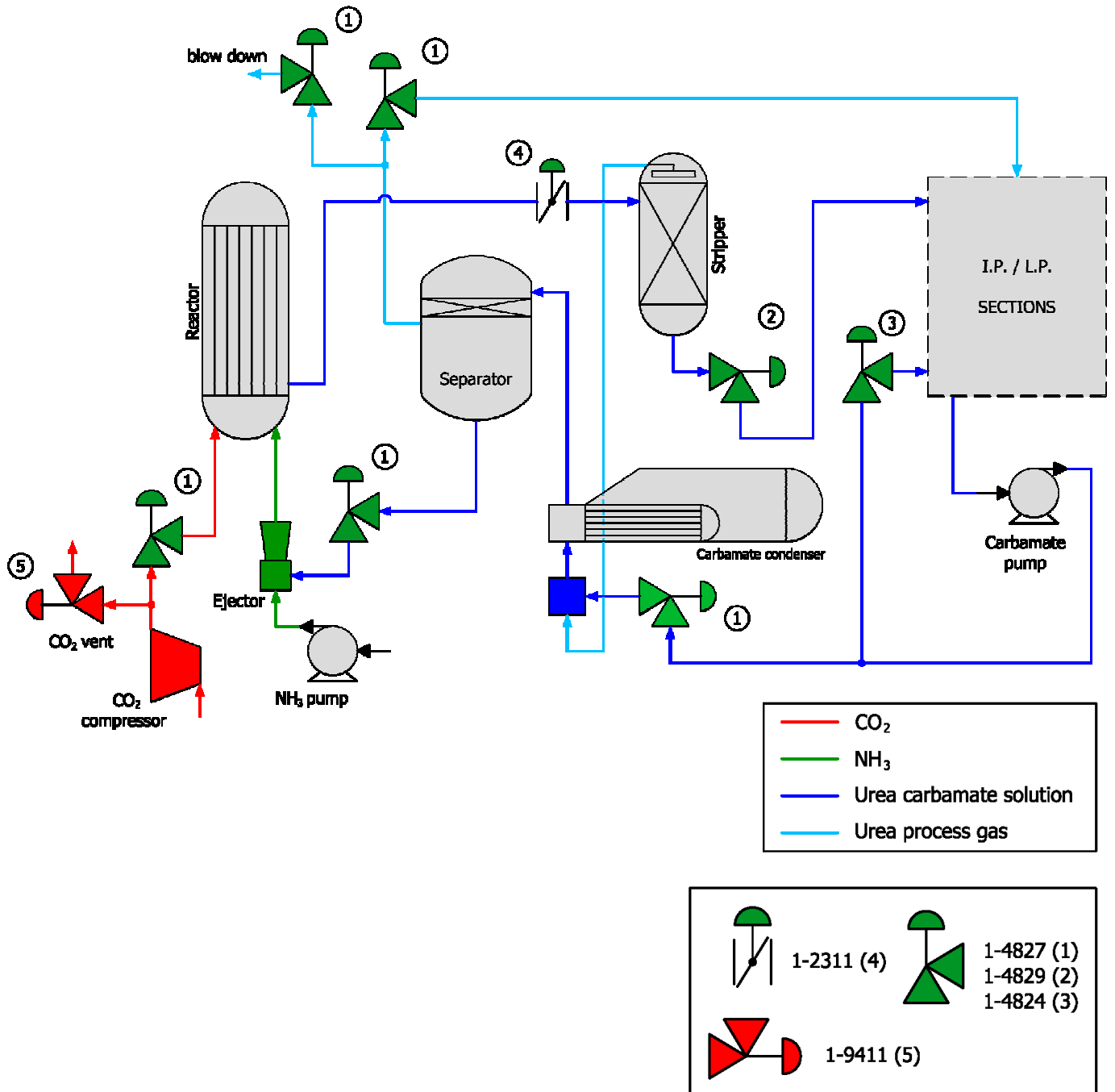

CO₂ STRIPPING UREA PROCESS TECHNOLOGY

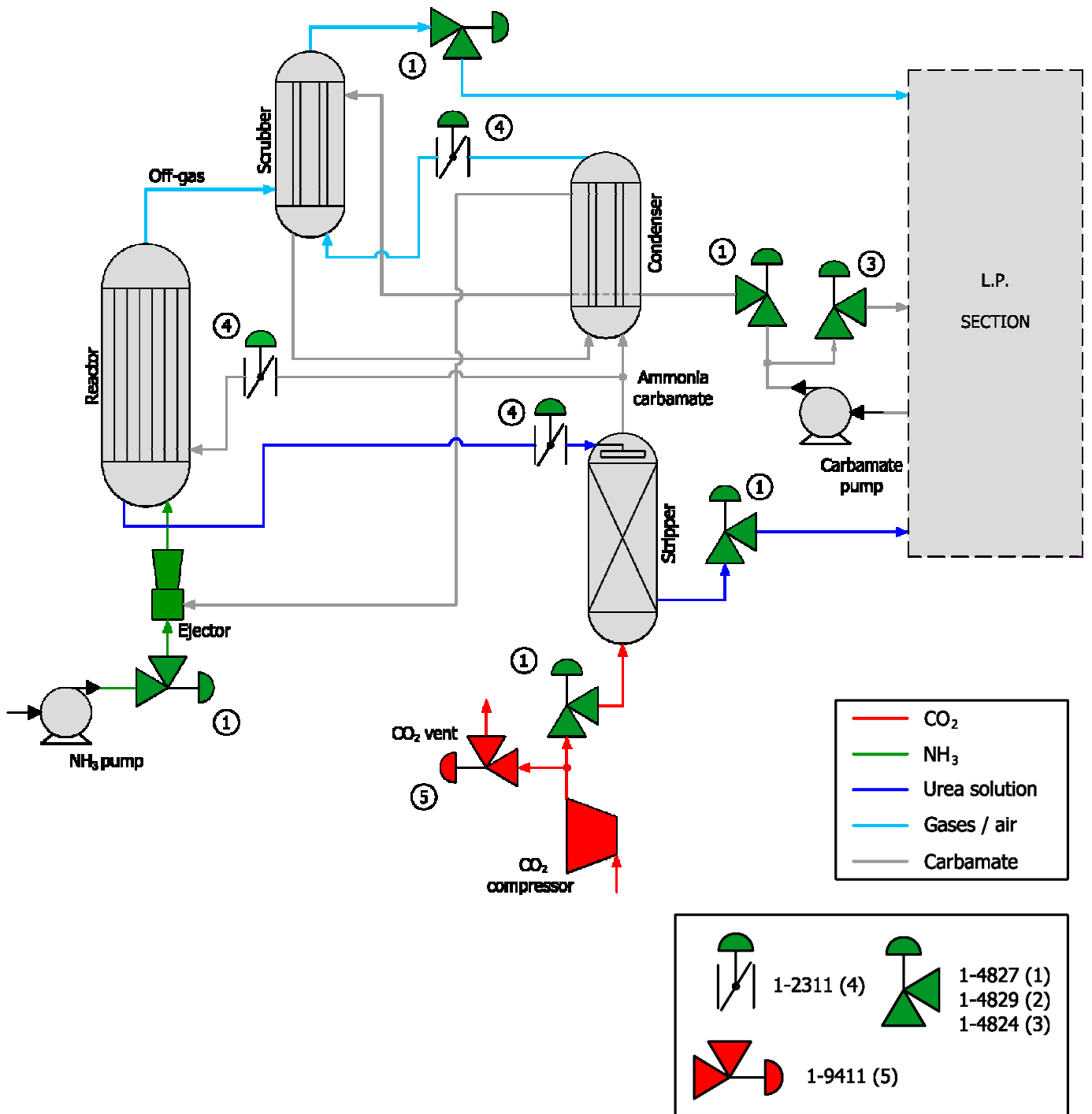

PARCOL

THE WORLD LEADER IN SEVERE SERVICE CONTROL VALVES FOR UREA PLANTS

- Technologically advanced and compact design.
- Proven experience on a large number of applications all over the world.
- Increased plant production due to high reliable valve performance and longer MTTM (Mean Time To Maintenance).
- Lowest overall costs due to:
 - easy maintenance, quick change trim, no screwed or welded seats;
 - long trim life;
 - Improved resistance to corrosion due to the absence of dead zones.
- Customized valve design to fit our valves in existing piping.
- Reduced leakage and system costs.

1-4800 SERIES SPLIT BODY ANGLE CONTROL VALVE

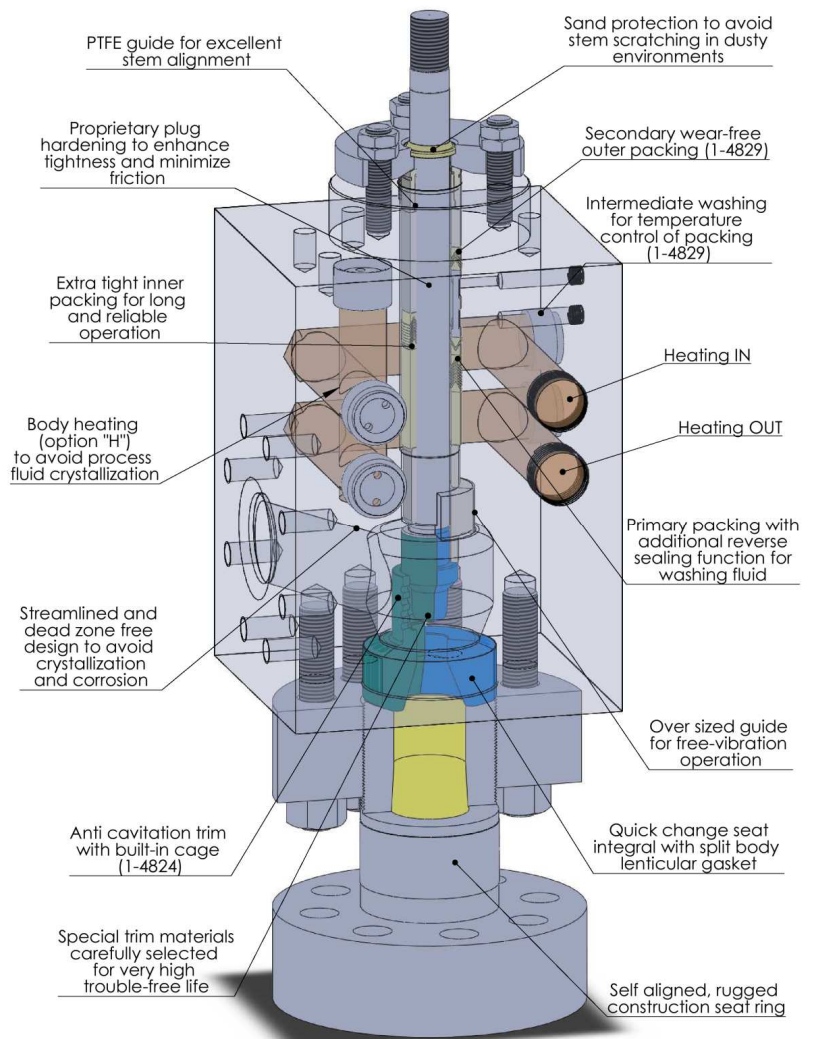

1-2311 SERIES ONE PIECE BODY BUTTERFLY CONTROL VALVE

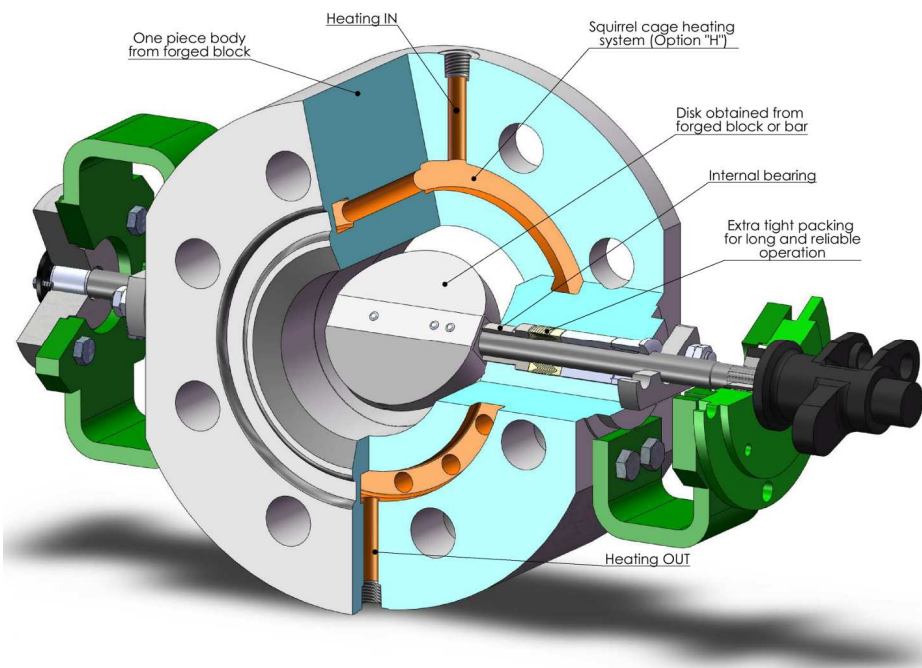

1-4800 SERIES MAIN SPECIFICATIONS**1-4827 (BASIC MODEL)****BODY**

- Style: split body angle design, streamlining design with integral bonnet.
- Construction: from forged block only.
- Materials: ASTM A182 F316L, AISI 316L modified for urea service and specialty duplex stainless steel (25Cr22Ni2Mo modified for urea service).
- Connections: flanged ends and stud bolts with lens-type seal according to Customer's std., flanged DIN and ANSI standard.
- Pressure ratings: ANSI 900 to 2500, DIN and UNI PN 160 to 400.
- Packing box: bolted type for adjustable loading of glass filled PTFE V-rings seal.
- Options: steam heating, companion flanges with BW connection, etc.

PLUG

- Sizes: full or reduced ports as per Cv's table.
- Construction: unit machined and polished plug and stem for perfect alignment and long life.
- Shapes: piston, contoured and disk for equal percentage, linear and quick opening flow characteristic.
- Guiding: top and port for piston plug and top only for other types.
- Materials: special duplex stainless steel (HVD-1, Ferralium, etc.).
- Seat face design: metal seated only with leakage class IV or V according to IEC 60534-4 (ANSI B16.104).

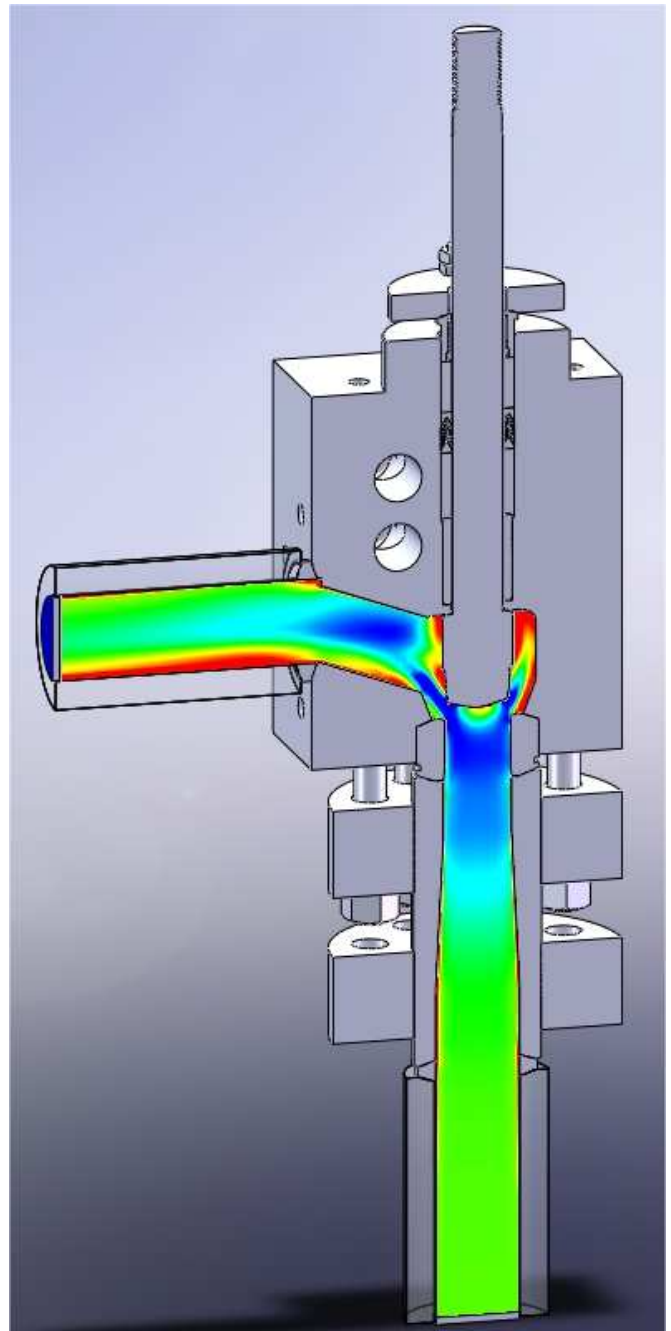
**1-4800 SERIES CFD ANALYSIS****GUIDE BUSHING**

- Style: long, heavy and precision fitted into the upper body.
 - Materials: as per plug ones with different hardness.
- SEAT**
- Style: quick change seat integral with split body lenticular gasket.
 - Materials: as per plug ones.

1-4829 (with PACKING WASHING)

Model 1-4829 control valves are similar to model 1-4827 but with a particular guide and packing design. As well known to instrument Engineers who work on urea plants, the crystallization of urea into packing box chamber result in detrimental effects both on integrity of packing sealing rings and polished surface of plug stem.

The combined effects of continuous washing device of upper part of packing box chamber with hot water at low pressure and special hardening and polishing of plug stem surface will avoid crystallization and packing leaks, and guarantee longer trouble-free-life of all trim and packing parts.

For main specifications please refer to the ones of model 1-4827 except for packing box construction with additional proprietary device for continuous washing of upper part of packing box chamber.

1-4824 (ANTI CAVITATION TRIM)

Model 1-4824 urea control valves are equal to model 1-4827 except for specialty multi stages trim expressly designed to avoid cavitation damages on high differential pressure services such as carbamate pump minimum recirculation flow.

Multi stage are realized on plug.

Last stage can be realized by a lenticular seat built-in cage.

Valve plug and drilled cage paths are designed in order to realize the most suitable expansion coefficient for any valve opening.



1-4827 SERIES VALVE WITH 1-X-212 PNEUMATIC DIAPHRAGM ACTUATOR AND COMPLETE WITH COMPANION FLANGES (OPTIONAL)

1-4827 series VALVE ASSEMBLY

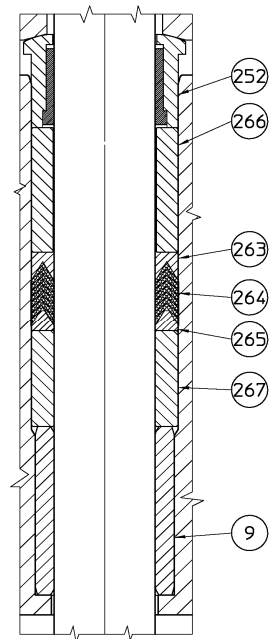
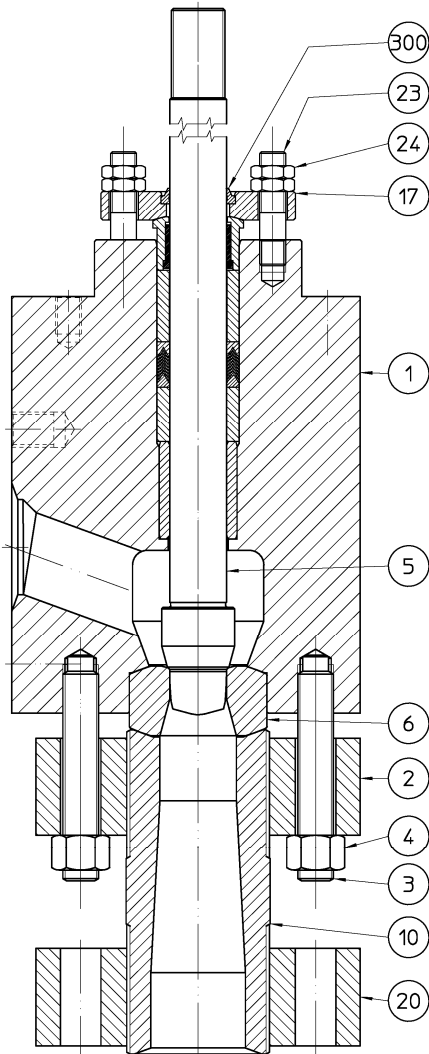

1-4827 AND 1-4824 PACKING DETAIL

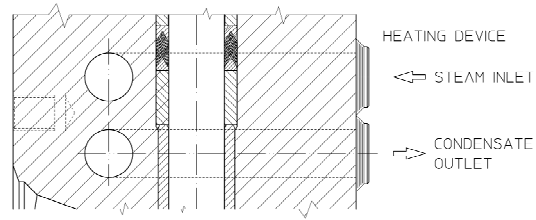

1-4827 AND 1-4824 HEATING DEVICE (OPTION H)

ITEM	PART NAME
1	BODY
2	FLANGE
3	STUD
4	NUT
5	PLUG
6	SEAT
9	GUIDE BUSHING
10	LOWER BODY
17	PACKING FLANGE
20	FLANGE

(B)
(B)

ITEM	PART NAME
23	STUD
24	NUT
252	PACKING FOLLOWER
263	HEAD RING
264	SEALING RING
265	PACKING END RING
266	SPACER
267	SPACER
300	SCRAPER

(A) (B)
(A) (B)
(A) (B)
(A) (B)
(A) (B)

(A) STRATUP - COMMISSIONING SUGGESTED SPARE PARTS
(B) STRATEGIC - TWO YEARS SUGGESTED SPARE PARTS

1-4829 series VALVE ASSEMBLY

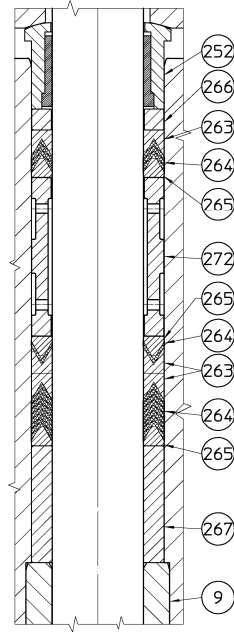
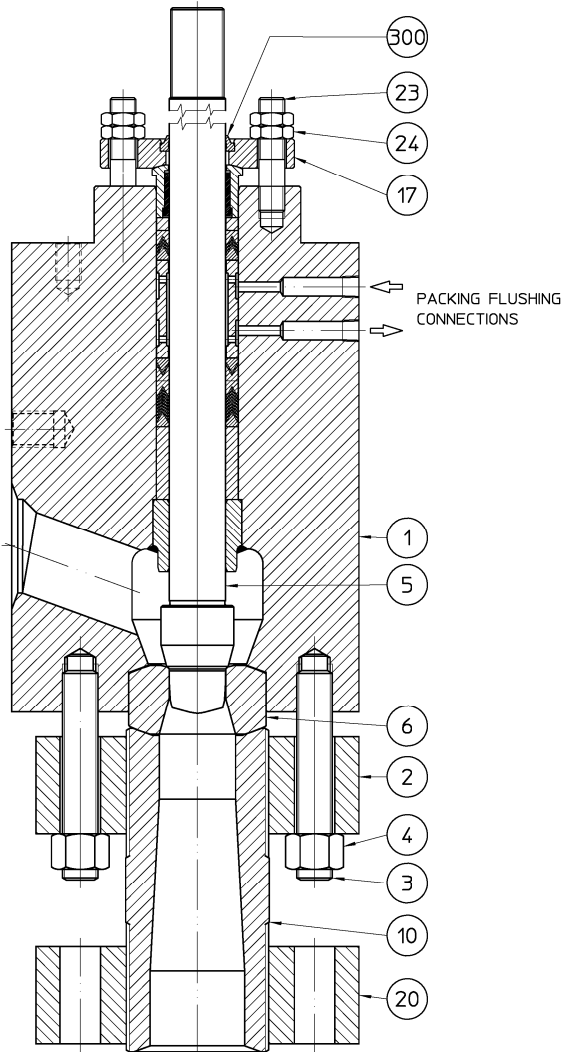

1-4829 PACKING DETAIL

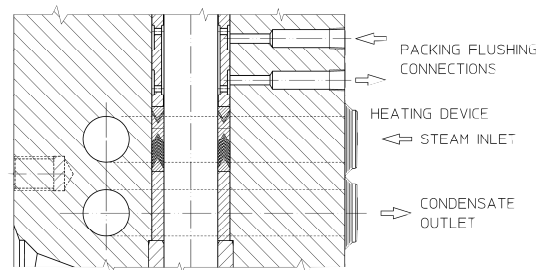

1-4829 HEATING DEVICE (OPTION H)

ITEM	PART NAME
1	BODY
2	FLANGE
3	STUD
4	NUT
5	PLUG
6	SEAT
9	GUIDE BUSHING
10	LOWER BODY
17	PACKING FLANGE
20	FLANGE

(B)
(B)

ITEM	PART NAME
23	STUD
24	NUT
252	PACKING FOLLOWER
263	HEAD RING
264	SEALING RING
265	PACKING END RING
266	SPACER
267	SPACER
272	FLUSHING FOLLOWER
300	SCRAPER

(A) (B)
(A) (B)
(A) (B)
(A) (B)
(A) (B)

(A) STRATUP - COMMISSIONING SUGGESTED SPARE PARTS
(B) STRATEGIC - TWO YEARS SUGGESTED SPARE PARTS

1-4824 series VALVE ASSEMBLY

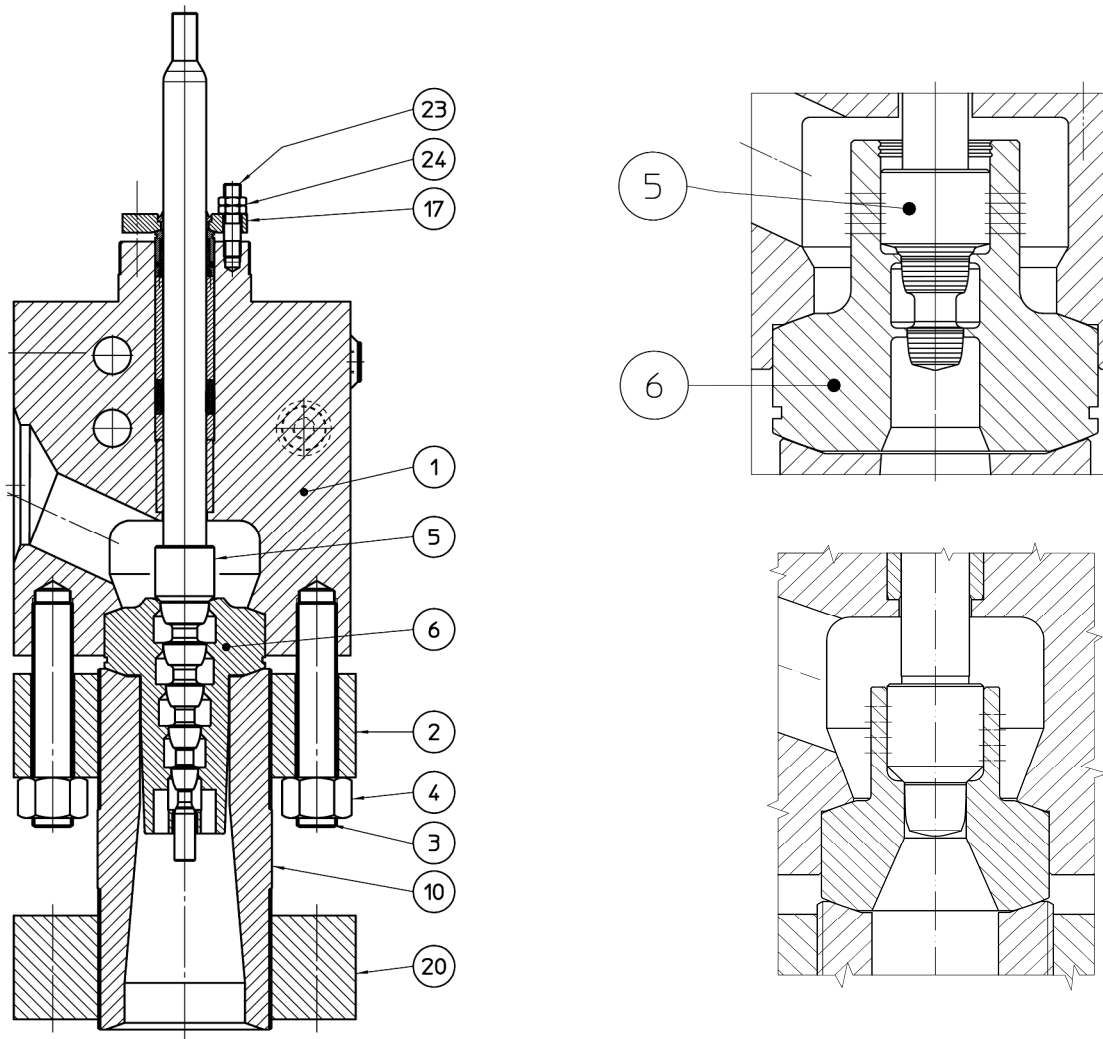

1-4824 MULTISTAGE PLUG DETAILS

ITEM	PART NAME
1	BODY
2	FLANGE
3	STUD
4	NUT
5	PLUG
6	SEAT
9	GUIDE BUSHING
10	LOWER BODY
17	PACKING FLANGE
20	FLANGE

ITEM	PART NAME
23	STUD
24	NUT
252	PACKING FOLLOWER
263	HEAD RING
264	SEALING RING
265	PACKING END RING
266	SPACER
267	SPACER
272	FLUSHING FOLLOWER
300	SCRAPER

(B)
(B)

(A) (B)
(A) (B)
(A) (B)
(A) (B)
(A) (B)

(A) STRATUP - COMMISSIONING SUGGESTED SPARE PARTS
(B) STRATEGIC - TWO YEARS SUGGESTED SPARE PARTS

1-4827 and 1-4829 FLOW COEFFICIENT Cv

DN in.	Port mm	Stroke mm	Regulating			On/Off		
			Travel 5%		Travel 100%		Travel 100%	
			FTO / FTC ⁽¹⁾	FTO	FTC	FTO	FTC	
3/4	3	17	0,003	0,02	0,024	-	-	
	4	17	0,011	0,05	0,06	-	-	
	8	17	0,027	0,25	0,30	-	-	
1	12	17	0,09	1,4	1,7	5,7	6,8	
	15	17	0,18	6,3	7,6	7,8	10	
	21	17	0,26	11	14	12	17	
1.1/2	12	25	0,09	3,3	4,0	5,7	6,8	
	15	25	0,18	7,7	9,4	9,0	11	
	19	25	0,17	12	15	13	17	
	23	25	0,29	17	21	18	23	
2	12	25	0,09	3,6	4,4	5,7	6,8	
	15	25	0,18	8,1	9,8	9,0	11	
	19	25	0,17	13	16	14	17	
	23	34	0,29	19	23	21	25	
	32	34	0,65	34	41	35	45	
3	19	34	0,17	13	16	14	17	
	23	34	0,29	18	22	21	25	
	28	34	0,57	28	34	31	37	
	35	34	0,71	44	52	47	58	
	47	34	1,24	74	89	69	89	
4	23	34	0,29	19	23	21	25	
	28	34	0,57	28	34	31	37	
	35	34	0,71	44	53	48	58	
	41	34	1,13	57	70	67	80	
	47	45	1,30	79	93	85	105	
6	60	45	1,82	122	147	124	159	
	35	45	0,71	44	53	48	58	
	41	45	1,13	59	73	67	80	
	47	45	1,30	79	96	87	105	
	57	45	1,73	111	136	128	154	
	65	45	1,97	150	179	163	200	
8	86	60	3,49	247	297	251	324	
	72	60	2,71	185	226	205	246	
	86	60	3,49	263	316	290	351	
	97	76	3,94	328	392	353	440	
	112	76	5,36	435	521	441	561	
10	86	76	3,49	263	322	292	351	
	97	76	3,94	335	409	372	446	
	112	76	5,36	447	535	490	595	
	130	76	6,66	581	697	624	781	
12	148	76	7,58	748	898	760	971	
	97	76	3,94	335	409	372	446	
	112	76	5,36	447	546	496	595	
	130	76	6,66	601	719	658	801	
	148	76	7,58	756	905	812	1.015	
	165	76	8,45	945	1133	960	1219	

**1-4827 SERIES VALVE WITH ELECTRIC ACTUATOR****1-4827 and 1-4829 RECOVERY FACTOR F_L and PRESSURE DIFFERENTIAL RATIO FACTOR x_T**

Travel	F_L		x_T	
	FTO	FTC	FTO	FTC
10%	0,94	0,80	0,83	0,51
100%	0,88	0,70	0,68	0,34

⁽¹⁾ FTO = Flow-To-Open; FTC = Flow-To-Close

1-4824 FLOW COEFFICIENT Cv

DN in.	Port mm	Stroke mm	Travel	
			5%	100%
1	15	17	0,18	4,4
	21	17	0,26	8,0
1.1/2	15	25	0,18	5,4
	19	25	0,17	8,7
	23	25	0,29	12
2	15	25	0,18	5,6
	19	25	0,17	9,0
	23	34	0,29	13
	32	34	0,65	24
3	19	34	0,17	9,0
	23	34	0,29	13
	28	34	0,57	20
	35	34	0,71	30
4	47	34	1,24	52
	23	34	0,29	13
	28	34	0,57	20
	35	34	0,71	30
	41	34	1,13	40
6	47	45	1,30	55
	60	45	1,82	86
	35	45	0,71	30
	41	45	1,13	42
6	47	45	1,30	55
	57	45	1,73	78
	65	45	1,97	105
	86	60	3,49	173

1-4824 RECOVERY FACTOR F_L

Travel	F_L
10%	0,94
100%	0,955



1-4827 SERIES VALVE WITH 1-X-432 PNEUMATIC CYLINDER ACTUATOR PROVIDED WITH SIDE-MOUNTED HANDWHEEL (OPTIONAL)

1-4800 series MAX DIFFERENTIAL PRESSURE ACROSS THE VALVE Δp - bar ⁽¹⁾

DN in.	Port mm	Stroke mm	Parcol Pneumatic actuator	Direct action (air to close)				Reverse action (air to open)											
				Spring range	Supply	Max Δp (class IV) bar	Max Δp (class V) bar	Spring range bar	Supply bar	Max Δp (class IV) bar	Max Δp (class V) bar								
3/4	3	17	1-X-210 D390	6÷30 psi	50 psi	325	325	15÷30 psi	35 psi	310	310								
	4	17																	
	8	17																	
1	12	17	1-X-210 D390	6÷30 psi	50 psi	325	325	15÷30 psi	35 psi	310	310								
	15	17								290	265								
	21	17	1-X-210 D450							300	285	235	215						
1.1/2	12	25	1-X-210 D390	6÷30 psi	50 psi	325	325	15÷30 psi	35 psi	300	290								
	15	25								290	270								
	19	25	1-X-210 D450							280	265								
	23	25								195	180								
2	12	25	1-X-210 D390	6÷30 psi	50 psi	325	325	15÷30 psi	35 psi	215	215								
	15	25								265	265								
	19	25	1-X-210 D450							325	325	280	265						
	23	34	1-X-210 D600											320	320				
	32	34	175											165					
3	19	34	1-X-210 D600	6÷30 psi	50 psi	325	325	15÷30 psi	35 psi	320	320								
	23	34								295	280	230	215						
	28	34								1-X-430 C450	1.5÷3 bar	6 bar	325	325	2.5÷4 bar	5 bar	325	310	
	35	34	220														215	185	175
	47	34	1-X-430 C600							250	245	210	200						
4	23	34	1-X-210 D600	6÷30 psi	50 psi	325	325	15÷30 psi	35 psi	320	320								
	28	34								295	280	230	215						
	35	34	1-X-430 C450							1.5÷3 bar	6 bar	325	325	2.5÷4 bar	5 bar	325	310		
	41	34														290	280	240	230
	47	45														220	210	185	175
	60	45														1-X-430 C600	250	245	210
6	35	45	1-X-430 C450	1.5÷3 bar	6 bar	325	325	2.5÷4 bar	5 bar							325	310		
	41	45														290	280	240	230
	47	45								205	205	170	170						
	57	45	1-X-430 C600							275	270	230	225						
	65	45								215	205	180	170						
8	72	60	1-X-430 C600	1.5÷3 bar	6 bar	175	170	2.5÷4 bar	5 bar	-	-								

⁽¹⁾ Pressure drop values reported in the above table refer to valves equipped with Parcol pneumatic actuators

1-4800 series OVERALL DIMENSIONS (mm)

DN in.	Port mm	Stroke mm	Actuator	A	B	C		D	E	F	G	H	L	M	N	P	V	Z	
						1-4824	1-4829										1-4829		
						1-4827	1-4829												
1.1/2	12	25	1-X-210 D390	75	231	79	109	35	30,5	43,5	95	4	22	3/4"	28	6	78	90	
	15		1-X-210 D450																
	19																		
	23																		
2	12	25	1-X-210 D390	90	265	89	131	45	39,3	53	110	4	25	7/8"	33	7	103	119	
	15		1-X-210 D450																
	19	34	1-X-210 D600																
	23																		
	32																		
3	19	34	1-X-210 D600	115	313	155	188	60	58,4	79	145	8	25	7/8"	33	7	127	156	
	23																		
	28		1-X-210 D450																
	35																		
	47																		
4	23	34	1-X-210 D600	135	410	157	185	75	77,2	103	185	8	32	1.1/8"	43	10	129	157	
	28																		
	35		1-X-430 C450																
	41	45	1-X-430 C600																
	47																		
	60																		
6	35	45	1-X-430 C450	165	525	193	223	100	116,4	152	255	8	41,5	1.1/2"	57	12	163	193	
	41																		
	47																		
	57		1-X-430 C600																
	65																		
	86	60																	
8	72	60	1-X-430 C600	205	638	205	265	120	153,1	196	320	8	51	1.7/8"	72	14	200	231	
	86																		
	97	76																	
	112																		
10	86	76	1-X-430 C600	235	755	240	278	140	190	241	380	8	55	2"	90	14	203	239	
	97																		
	112																		
	130																		
	148																		
12	97	76	1-X-430 C600	280	897	288	288	186	232	292	485	12	48	1.3/4"	70	14	206	242	
	112																		
	130																		
	148																		
	165																		

BODY HEATING and PACKING WASHING DETAILS (mm)

DN in.	CONNECTION	a	b	d	e	f	g	h	m
1.1/2	1/2" NPT	7	41	44	33	70	65	-	-
	1/2" ANSI 150/300 RF					-	-	123	118
2	1/2" NPT	16	52	55	37	80	75	-	-
	1/2" ANSI 150/300 RF					-	-	133	128
3	1/2" NPT	47	95	60	60	108	108	-	-
	1/2" ANSI 150/300 RF					-	-	153	153
4	1/2" NPT	52	100	78	70	133	128	-	-
	1/2" ANSI 150/300 RF					-	-	178	173
6	1/2" NPT	55	125	115	70	173	168	-	-
	1/2" ANSI 150/300 RF					-	-	218	213
8	1/2" NPT	75	145	150	85	213	203	-	-
	1/2" ANSI 150/300 RF					-	-	258	248
10	1/2" NPT	65	150	135	85	248	203	-	-
	1/2" ANSI 150/300 RF					-	-	293	248
12	1/2" NPT	88	168	150	90	295	238	-	-
	1/2" ANSI 150/300 RF					-	-	340	283

WEIGHTS (kg)

DN in.	1-4824 1-4827	1-4829
1.1/2	35	40
2	55	65
3	115	130
4	215	230
6	445	470
8	780	855
10	1060	1130
12	1870	1870

Above dimensions and weights refer to valves flanged PN 325 with lenticular gasket. Dimensions and weights can change depending on licensor applicable standards.

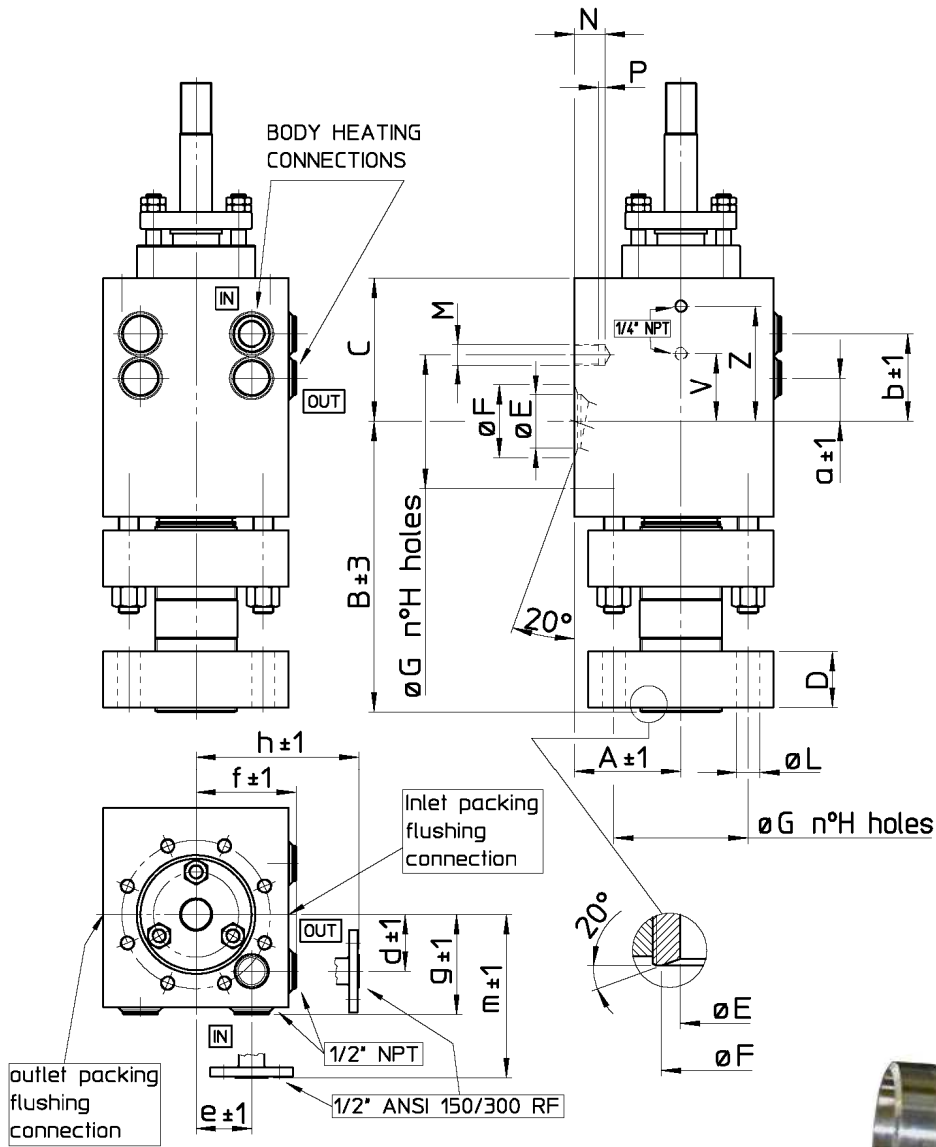

**1-4827 SERIES VALVE DN 8" WITH
DOUBLE ACTING SPRING RETURN PNEUMATIC CYLINDER ACTUATOR
AND COMPLETE WITH COMPANION FLANGES (OPTIONAL)**

1-2311 AND 1-2611 MAIN SPECIFICATIONS**BODY**

- Style: swing-through type with threaded holes.
- Construction: from forged block only.
- Materials: specialty duplex stainless steel 25Cr22Ni2Mo modified for urea service.
- Connections: flanged ends with lens-type seal according to Customer's std., flanged DIN and ANSI standard.
- Pressure ratings: ANSI 900 to 2500, DIN and UNI PN 160 to 400.
- Packing box: double side, bolted type for adjustable loading of glass filled PTFE V-rings seal.
- Options: steam heating, etc.

DISC

- Construction: machined from forged block or bar only.
- Materials: special duplex stainless steel (HVD-1, Ferralium, etc.).
- Leakage class:
 - For 1-2311:
 - class II according to IEC 60534-4 (ANSI B16.104);
 - leakage class III with metal seated special execution (70° opening);
 - with calibrated orifice when minimum flow is required in closed position.
 - For 1-2611:
 - class IV according to IEC 60534-4 (ANSI B16.104);

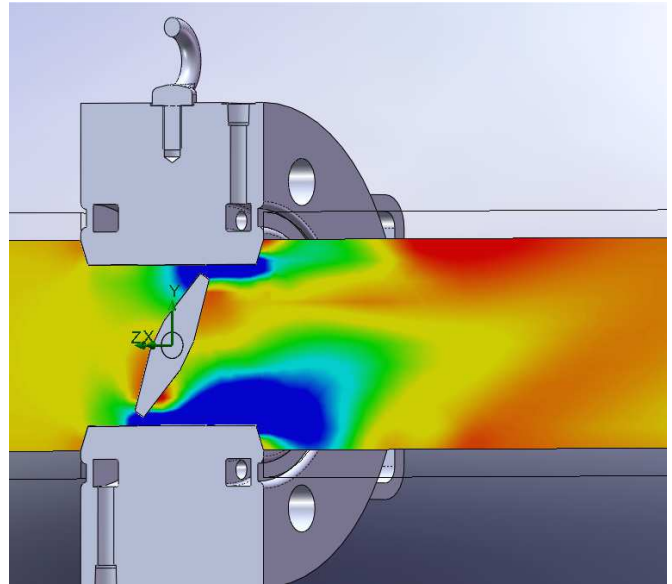
**1-2311 SERIES CFD ANALYSIS****BEARINGS**

- Style: metal bearings inside valve body, additional PTFE lined external bearings.
- Materials:
 - internal bearings: as per shaft ones with different hardness
 - external bearings: PTFE lined carbon steel.

SHAFT

- Materials: special duplex stainless steel (HVD-1, Ferralium, etc.).

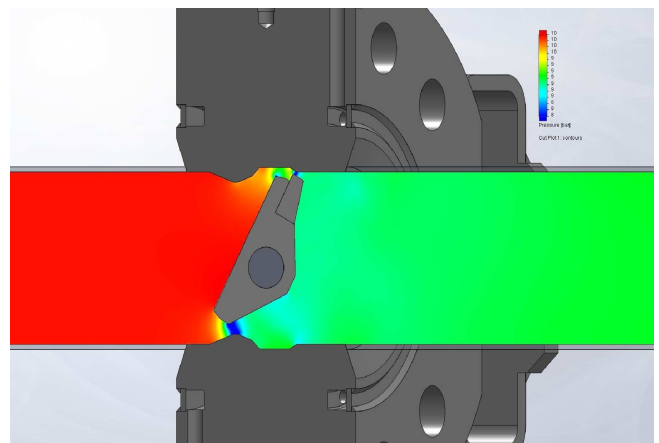
**1-2611 SERIES CFD ANALYSIS**

1-2311 series VALVE ASSEMBLY

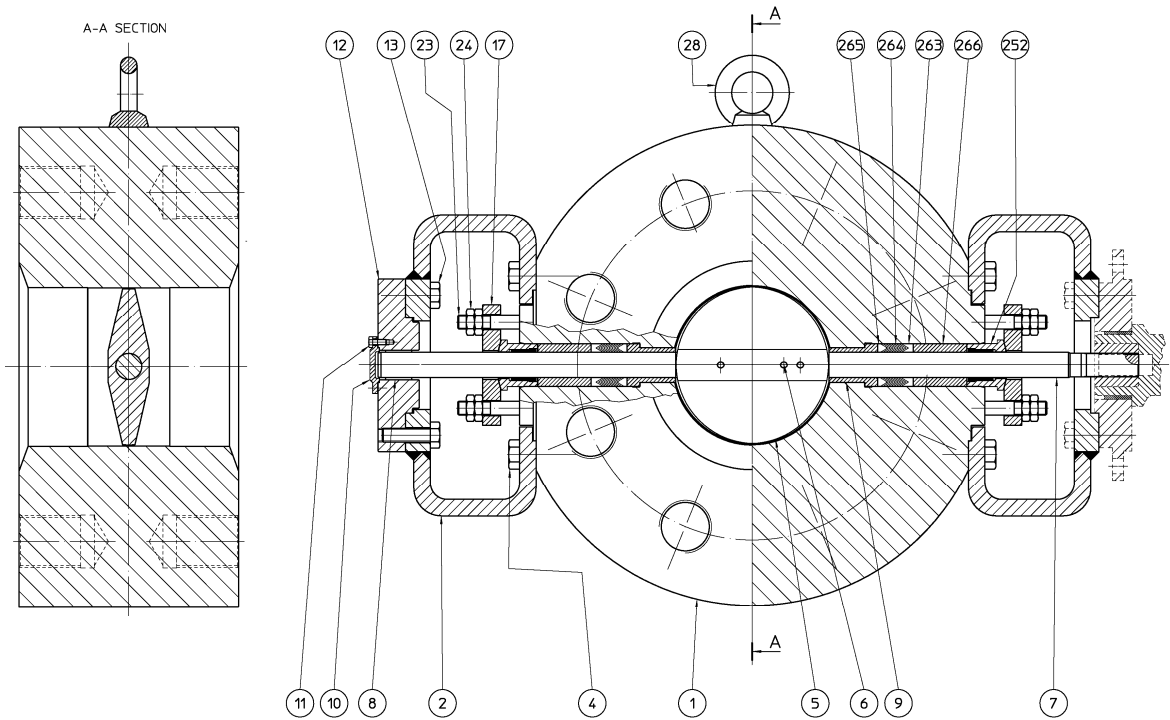

ITEM	PART NAME
1	BODY
2	ACTUATOR BASKET
4	SCREW
5	VANE
6	PIN
7	SHAFT
8	BUSHING
9	GUIDE BUSHING
10	COVER
11	SCREW
12	BLIND FLANGE

ITEM	PART NAME
13	SCREW
17	PACKING FLANGE
23	STUD
24	NUT
(B) 28	EYEBOLT
(B) 252	PACKING FOLLOWER
(B) 263	HEAD RING
(B) 264	SEALING RING
(B) 265	PACKING END RING
(B) 266	SPACER

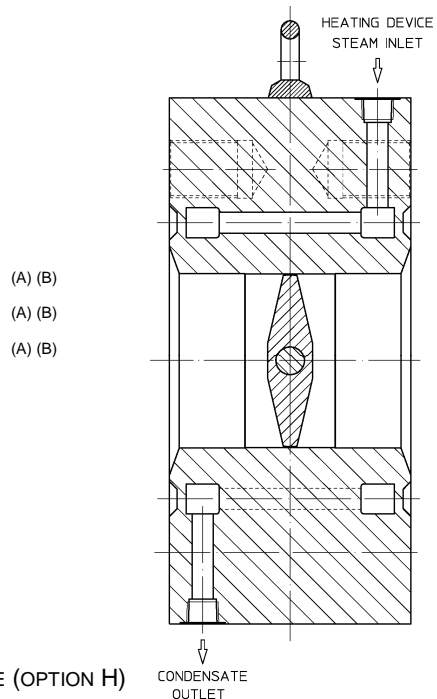

1-2311 HEATING DEVICE (OPTION H)

(A) STRATUP - COMMISSIONING SUGGESTED SPARE PARTS
 (B) STRATEGIC - TWO YEARS SUGGESTED SPARE PARTS

1-2311 series FLOW COEFFICIENT C_v ⁽¹⁾

DN in.	DN mm	Cv max 90°	Opening angle ⁽²⁾⁽³⁾								
			5°	10°	20°	30°	40°	50°	60°	70°	80°
4	100	300	2,5	3	8	20	41	70	116	183	254
6	150	850	9,5	10	23	56	115	199	329	518	721
8	200	1460	12,5	13	40	96	198	341	565	890	1238
10	250	2190	16	19.5	60	144	297	511	847	1335	1857

RECOVERY FACTOR F_L

DN in.	DN mm	F_L 90°	Opening angle								
			5°	10°	20°	30°	40°	50°	60°	70°	80°
4	100	0,58	0,95	0,95	0,94	0,91	0,86	0,81	0,74	0,67	0,61
6	150	0,54	0,95	0,95	0,93	0,90	0,84	0,78	0,71	0,63	0,57
8	200	0,54	0,95	0,95	0,93	0,90	0,85	0,78	0,71	0,63	0,57
10	250	0,59	0,95	0,95	0,93	0,90	0,87	0,83	0,78	0,72	0,65

PRESSURE DIFFERENTIAL RATIO FACTOR x_T

DN in.	DN mm	x_T	
		90°	10°
4	100	0,24	0,85
6	150	0,20	0,84
8	200	0,21	0,84
10	250	0,24	0,85

MAX DIFFERENTIAL PRESSURE ACROSS THE VALVE Δp - bar ⁽⁴⁾

Parcol Pneumatic actuator 1-X-271	Opening angle (°)		
	0 ÷ 30	60	80 ÷ 90
D33	30	30	9
D39	30	25	5
D46	30	18	4
D46	30	10	2

1-2311 FLOW CHARACTERISTIC

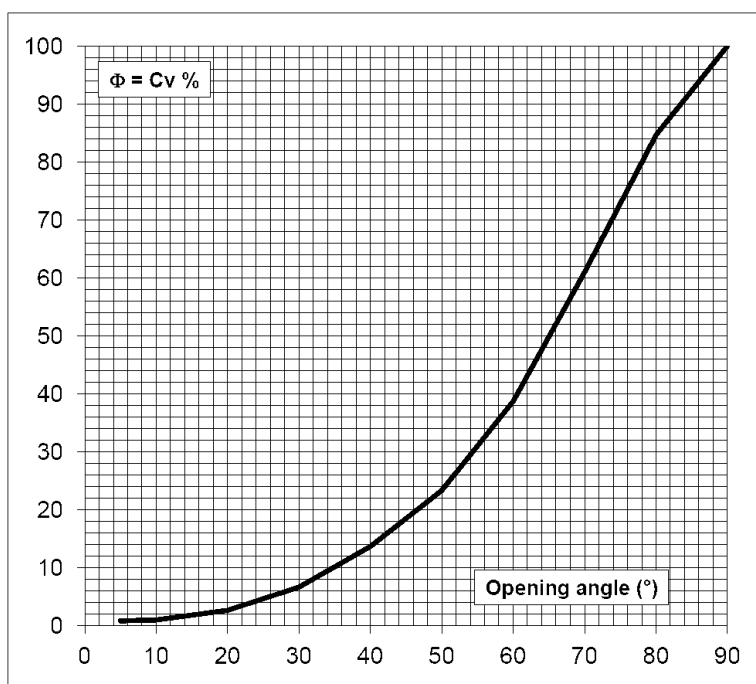

(1) C_v are expressed in U.S. gallons/min. of water with $\Delta p=1$ psi
 (2) Rangeability can be calculated as $C_v \text{ max}/C_v \text{ 5°}$
 (3) Tolerance according to IEC 60534-2-4
 (4) Intermediate values can be obtained by linear interpolation

1-2311 series OVERALL DIMENSIONS (mm) and WEIGHTS (kg)

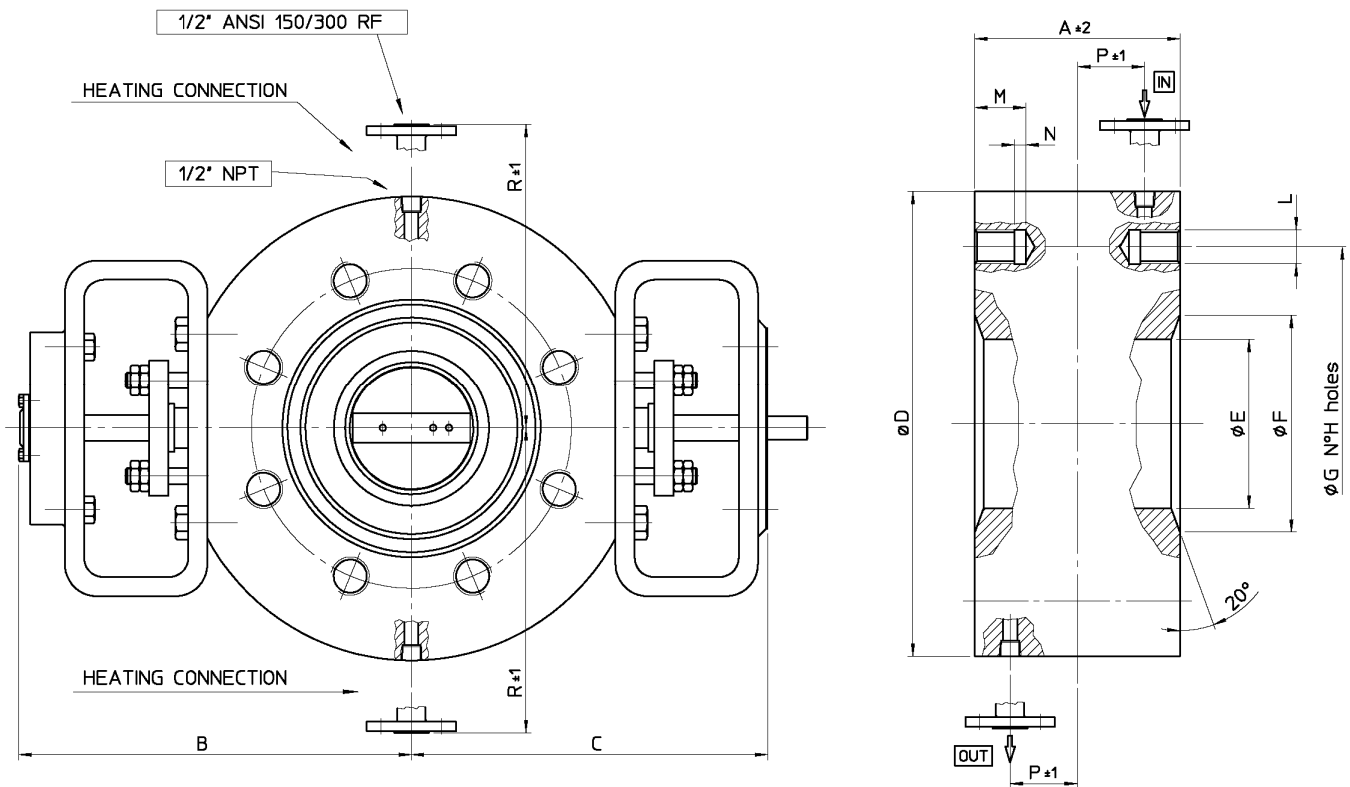

DN in.	Port mm	Parcol Pneumatic Actuator	A	B	C	D	E	F	G	H	L	M	N	P	R	WEIGHT
4	77,2	1-X-271 D33	140	244	218	290	77,2	103	185	8	1.1/8"	43	10	48	198	71
6	116	1-X-271 D39	160	279	253	350	116,4	152	255	8	1.1/2"	57	12	58	228	113
8	152,8	1-X-271 D46	185	342	307	440	153,1	196	320	8	1.7/8"	72	14	71	273	207
10	190	1-X-271 D46	225	384	349	520	190,4	241	380	8	2"	90	14	91	313	342

Above dimensions and weights refer to valves flanged PN 325 with lenticular gasket. Dimensions and weights can change depending on licensor applicable standards.

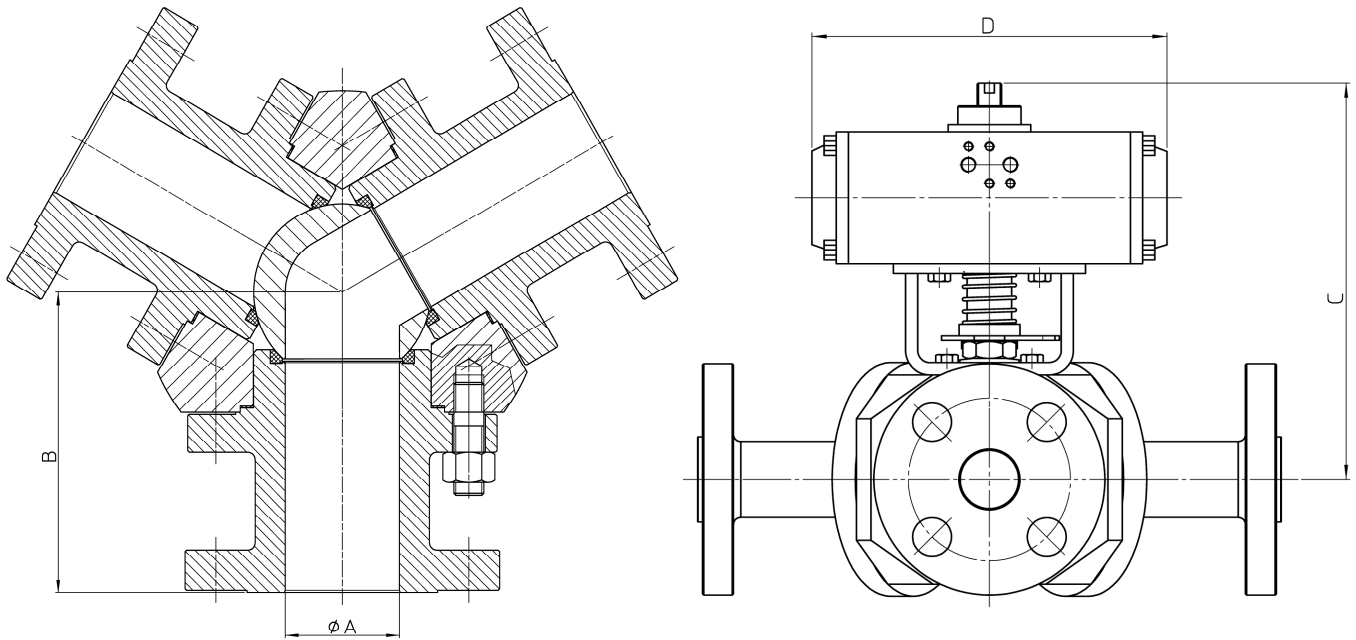

1-2311 VALVE WITH PARCOL 1-X-271 PNEUMATIC DIAPHRAGM ACTUATOR PROVIDED WITH TOP-MOUNTED HANDWHEEL (OPTIONAL)

4-3111 THREE WAYS BALL VALVE**OVERALL DIMENSIONS (mm) AND WEIGHTS (kg)**

DN	ANSI	Ø A	B	C	D	WEIGHT
1"	150	24	95	190	205	32
	300					
1.1/2"	150	38	110	300	251	40
	300		130			53
2"	150	48	120	300	251	55
	300		150			69
3"	150	75	150	320	430	87
	300		200			122
4"	150	94	165	360	430	117
	300		215			146

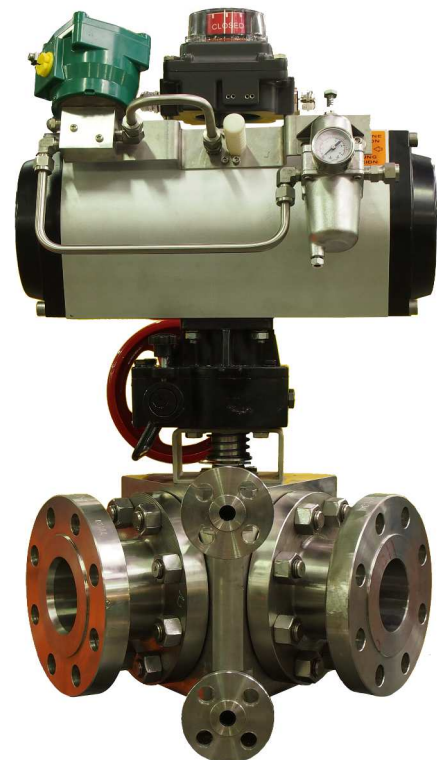
**4-3111 VALVE WITH PNEUMATIC ACTUATOR**

1-X-210 series DIAPHRAGM ACTUATOR

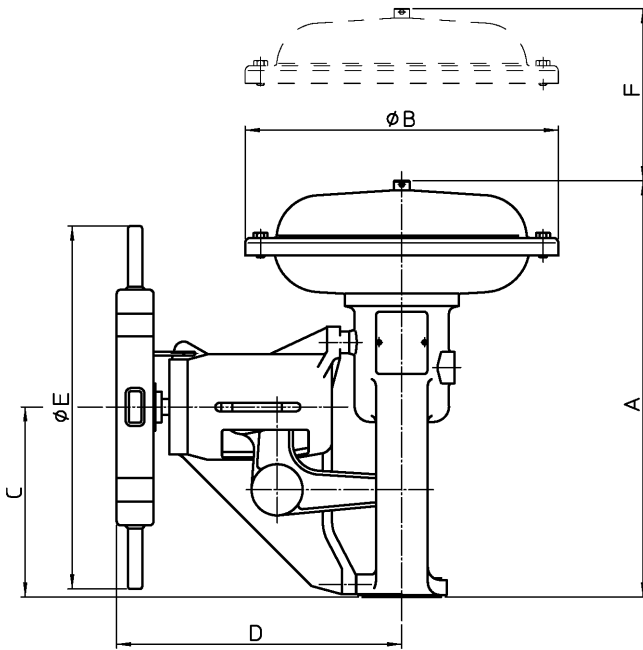

WITH SIDE-MOUNTED HANDWHEEL (OPTION)

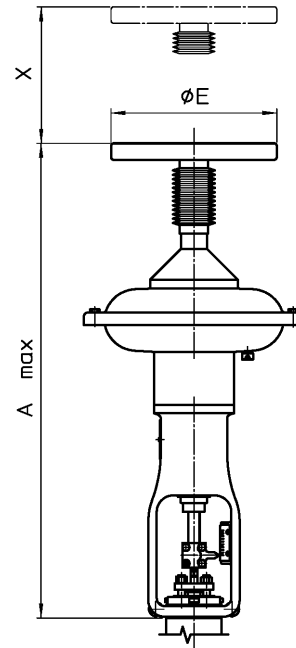

WITH TOP-MOUNTED HANDWHEEL (OPTION)

OVERALL DIMENSIONS (mm) AND WEIGHTS (kg)

TYPE	A		F	B	Side handwheel			Top handwheel			
	DIRECT ⁽¹⁾	REVERSE ⁽¹⁾			C	D	E	A max		E	X
								DIRECT ⁽¹⁾	REVERSE ⁽¹⁾		
D250	398	461	150	266	200	300	380	570	665	175	150
D310	412	494	150	325	200	300	380	590	700	225	150
D390	511	662	200	400	241	360	470	795	965	300	200
D450	584	750	250	482	252	365	470	925	1080	400	250
D600	754	954	300	631	330	455	570	-	-	-	-

TYPE	ACTION ⁽¹⁾	WEIGHT		
		Standard	Side handwheel	Top handwheel
D250	DIRECT	15	25	20
	REVERSE	16	26	22
D310	DIRECT	16	26	21
	REVERSE	19	29	25
D390	DIRECT	29	48	41,5
	REVERSE	39	58	54
D450	DIRECT	48	67	60,5
	REVERSE	63	82	78
D600	DIRECT	100	135	-
	REVERSE	130	165	-



1-X-210 SERIES PNEUMATIC DIAPHRAGM ACTUATORS PROVIDED WITH TOP-MOUNTED AND SIDE-MOUNTED HANDWHEEL (OPTIONAL)

⁽¹⁾ DIRECT = 1-X-211; REVERSE = 1-X-212

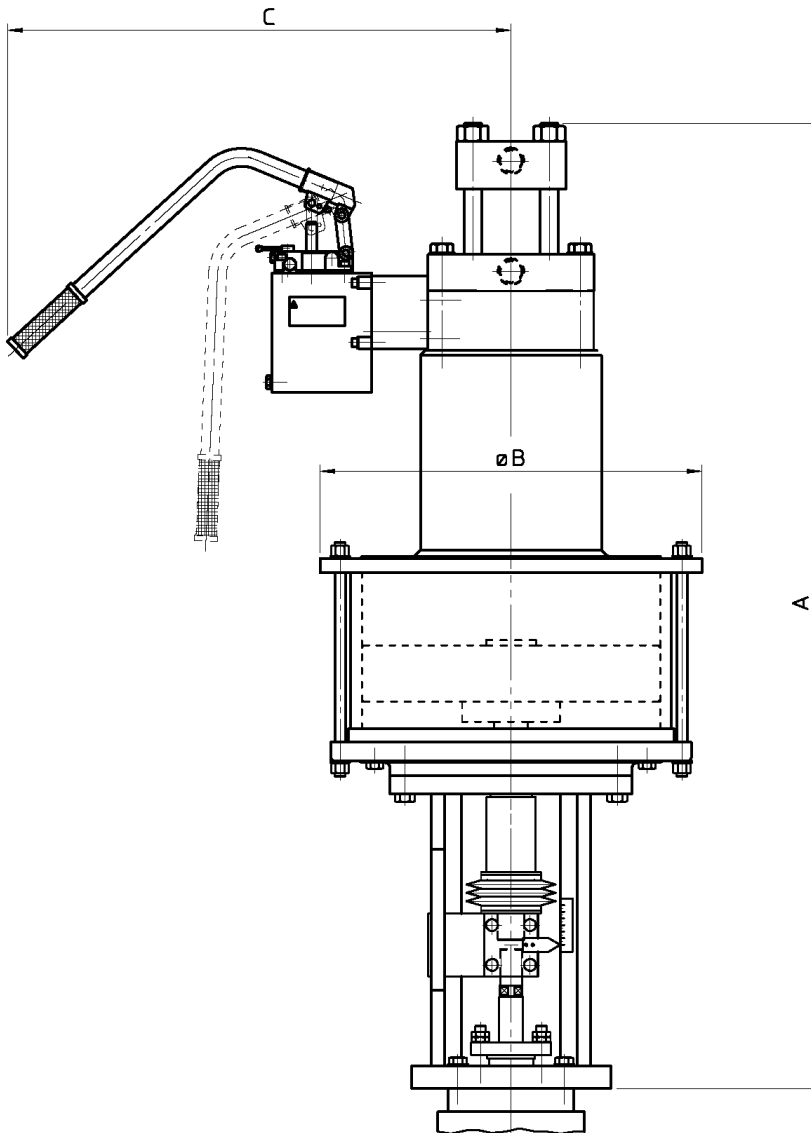
1-X-430 series PNEUMATIC CILYNDER ACTUATOR OVERALL DIMENSIONS (mm) and WEIGHTS (kg)

TYPE	CYLINDER STROKE mm	VALVE STROKE mm	A	B	C	WEIGHT ⁽¹⁾
C450	100	< 45	1459	575	905	280
C600	100	< 76	1618	748	905	690

⁽¹⁾ Without hydraulic manual operator

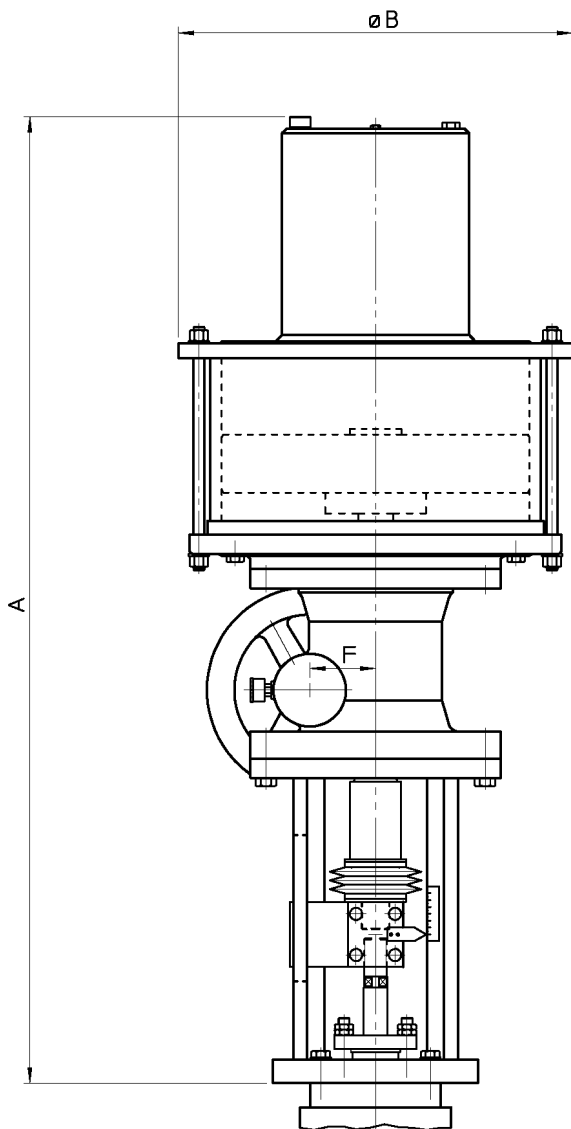
1-X-430 series PNEUMATIC CILYNDER ACTUATOR OVERALL DIMENSIONS (mm) and WEIGHTS (kg)

**1-X-432 SERIES PNEUMATIC CYLINDER
ACTUATOR PROVIDED WITH SIDE-MOUNTED
HANDWHEEL (OPTIONAL)**

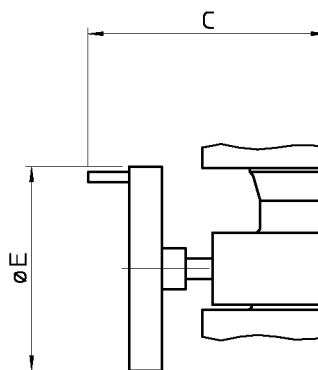

TYPE	CYLINDER STROKE mm	VALVE STROKE mm	A	B	C	E	F	WEIGHT ⁽¹⁾
C450	100	< 45	1409	575	350	300	96	280
C600	100	< 76	1580	748	380	375	118	690

⁽¹⁾ Without handwheel operator

1-X-271 SERIES PNEUMATIC DIAPHRAGM ACTUATORS

1-X-271 series rotary pneumatic diaphragm actuator is normally installed on PARCOL rotary valves (0° ÷ 90°). D25, D33, D39, D46 and D63 sizes are available.

Floating stem construction minimizes frictions and backlash and significantly reduces mass and dimensions.

The spring is preloaded in a suitable case, to make diaphragm replacement safer and simpler.

The design allows replacing the actuator without disassembling the valve or part of it.

Standard diaphragm settings are 3÷15 psi (0.2÷1 bar), 6÷30 psi (0.4÷2 bar), 20÷44 psi (1.4÷3 bar) with 20÷50 psi (1.4÷3.5 bar) supply in air-to-open and air-to-close flow directions.

Other spring ranges are available on request.

Max operating pressure = 3.5 bar (50 psig). Should this pressure limit be exceeded, internal parts of actuator can be permanently deformed.

The case and the relevant joints can withstand a pressure of 10 bar at least without significant permanent deformations (PED certification: PS = 6 bar).

Bursting pressure = over 30 bar.

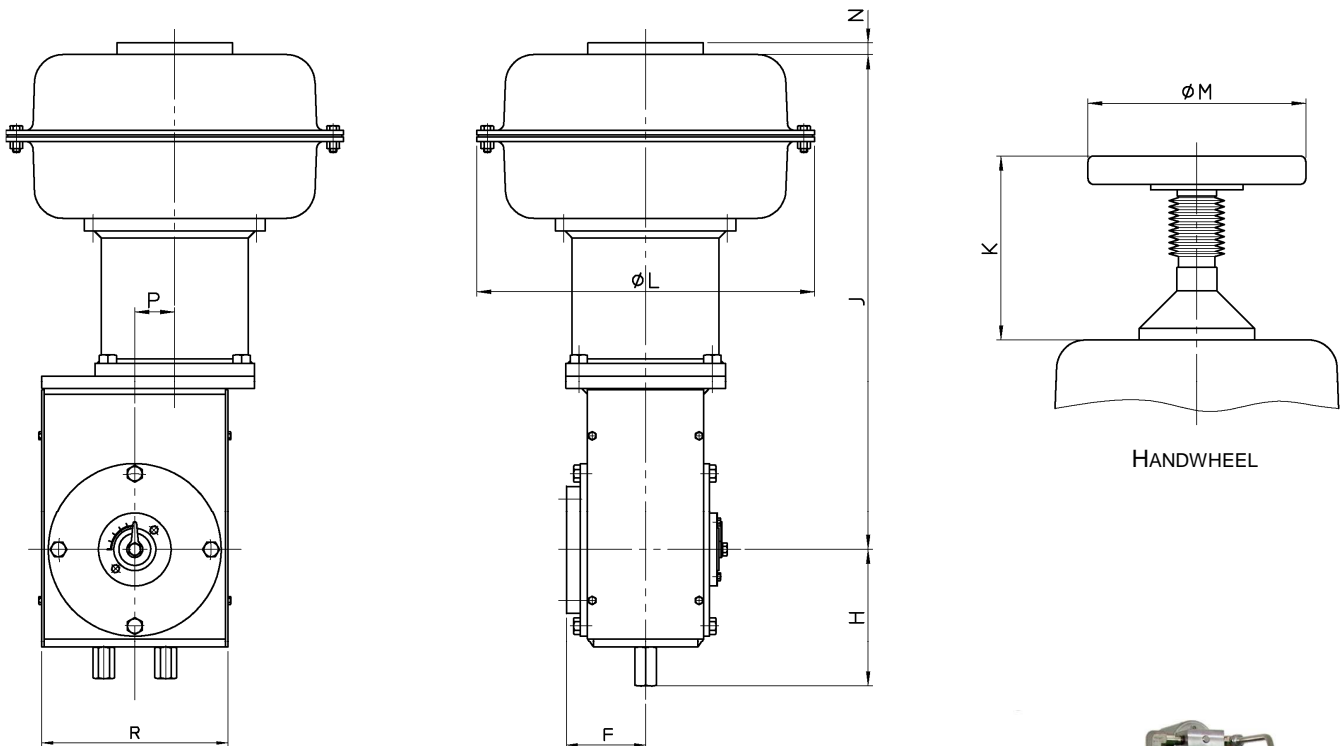

OVERALL DIMENSIONS (mm) AND WEIGHTS (kg)

1-X-271 ACTUATOR	F	H	J	K	L	M	N	P	R	WEIGHT ⁽¹⁾
D25	65	112	432	220	262	175	21	29	140	28
D33	78	140	538	255	333	225	21	36	170	50
D39	96	170	639	343	395	300	24	46	224	85
D46	109	190	731	397	465	400	24	55	250	140
D63	155	275	836	520	640	570	21	72	300	180



⁽¹⁾ Without handwheel operator

1-X-271 SERIES PNEUMATIC DIAPHRAGM ACTUATOR PROVIDED WITH STROKE LIMITOR

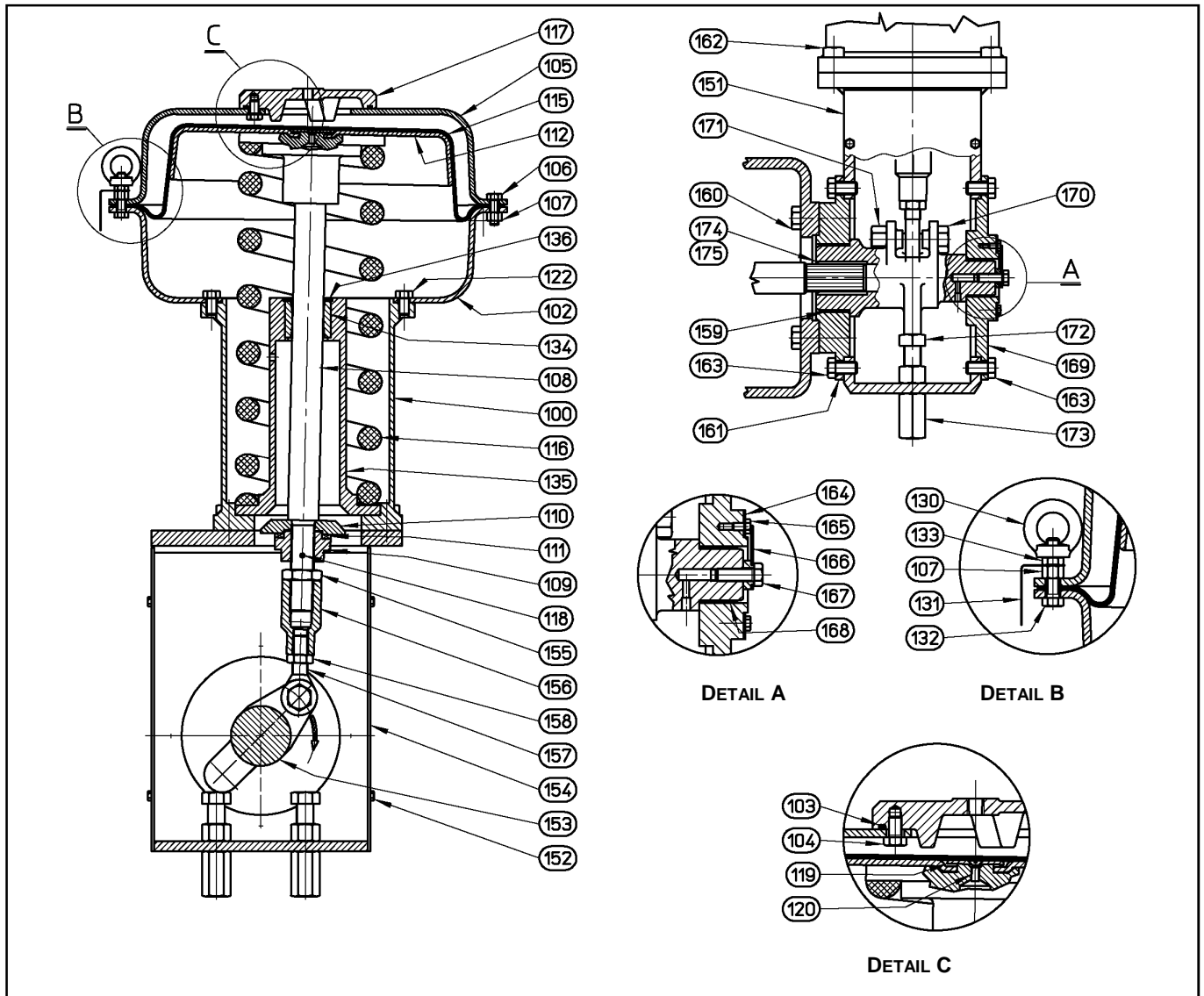

1-X-271 SERIES D33-D46 TYPE DIAPHRAGM ACTUATOR

ITEM	PART NAME
100	SPRING CASE
102	LOWER DIAPHRAGM CASE
103	"O" RING
104	SCREW
105	TOP DIAPHRAGM CASE
106	SCREW
107	NUT
108	STEM AND SPRING GUIDE
109	CLAMPING NUT
110	SPACER
111	BEARING
112	DIAPHRAGM PLATE
115	DIAPHRAGM
116	SPRING
117	CAP
118	SPRING
119	WASHER
120	SCREW
121	SPACER RING
122	SCREW
130	EYEBOLT
131	EYEBOLT PLATE
132	SCREW
133	NUT
134	GUIDE BUSHING
135	LOWER SPRING SEAT

ITEM	PART NAME
136	STOP RING
151	YOKE
152	SCREW
153	LEVER
154	SIDE COVER
155	NUT
156	SCREW COUPLING
157	LEFT THREADED BALL JOINT
158	NUT
159	BEARING
160	SCREW
161	COVER
162	SCREW
163	SCREW
164	PLATE
165	SCREW
166	TRAVEL INDICATOR
167	SCREW
168	BEARING
169	COVER
170	SCREW
171	NUT
172	SCREW
173	NUT
174	BUSHING
175	PIN

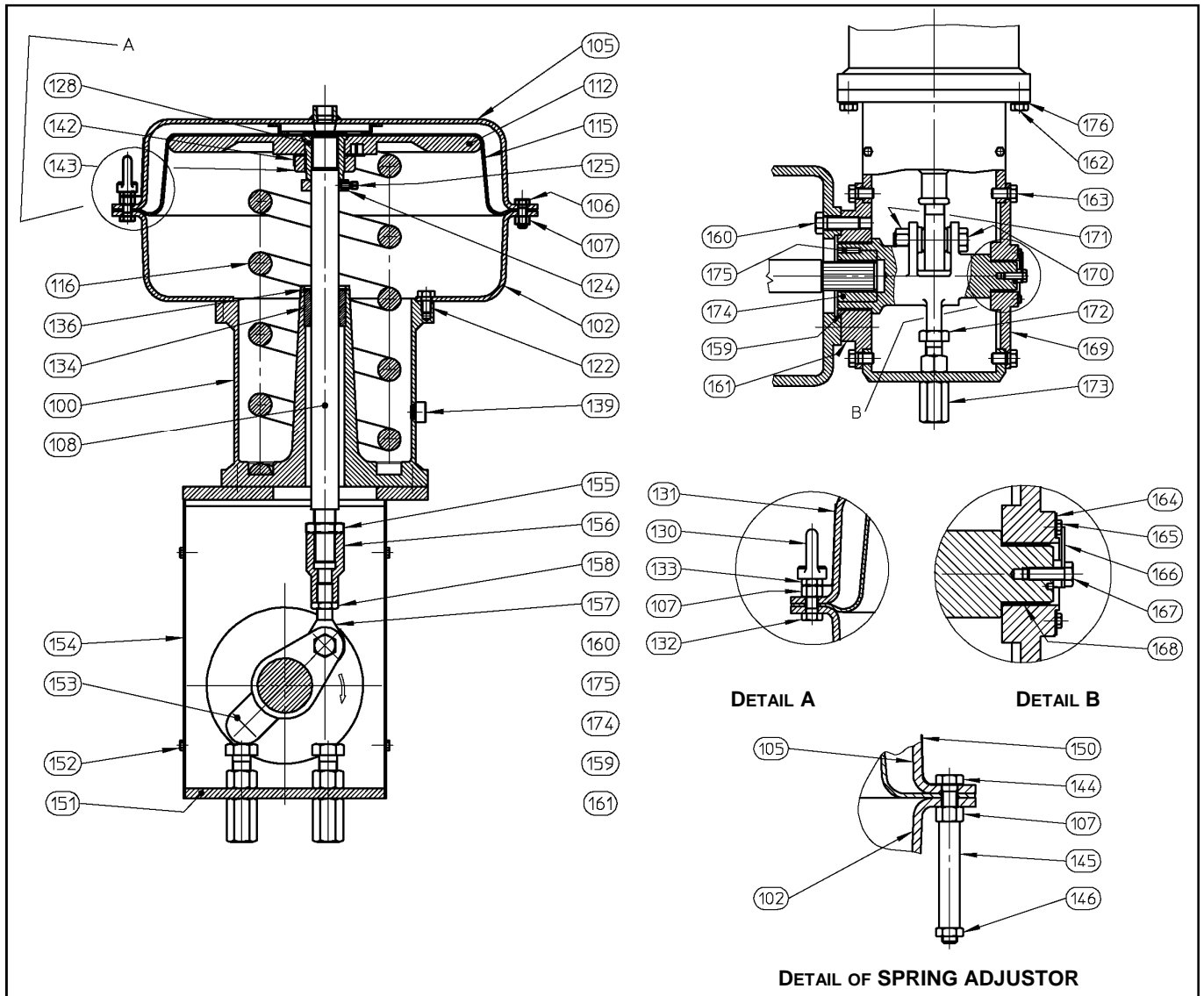

1-X-271 SERIES D63 TYPE DIAPHRAGM ACTUATOR

ITEM	PART NAME
100	YOKE
102	LOWER DIAPHRAGM CASE
105	UPPER DIAPHRAGM CASE
106	SCREW
107	NUT
108	STEM
112	DIAPHRAGM PLATE
115	DIAPHRAGM
116	SPRING
122	SCREW
124	STROKE LIMITER
125	SCREW
128	NUT
130	EYEBOLT
131	EYEBOLT PLATE
132	SCREW
133	NUT
134	GUIDE BUSHING
136	STOP RING
139	VENT PLUG
142	WASHER
143	CLAMPING NUT
144	SPRING ADJUSTOR
145	THREADING PROTECTION
146	NUT
150	PLATE

ITEM	PART NAME
151	ACTUATOR SUPPORT
152	SCREW
153	LEVER
154	SIDE COVER
155	NUT
156	JOINT
157	BALL JOINT
158	NUT
159	BEARING
160	SCREW
161	COVER
162	SCREW
163	SCREW
164	PLATE
165	SCREW
166	TRAVEL INDICATOR
167	SCREW
168	BEARING
169	COVER
170	SCREW
171	NUT
172	SCREW
173	NUT
174	BUSHING
175	PIN
176	WASHER



PARCOL S.p.A. Via Isonzo, 2 - 20010 CANEGRATE (MI) - ITALY
Telephone: +39 0331 413.111 - Fax: +39 0331 404.215
E-mail: sales@parcol.com - <http://www.parcol.com>